

LONGTECH BLOWER

ROOTS TYPE BLOWER & VACUUM PUMP CATALOG

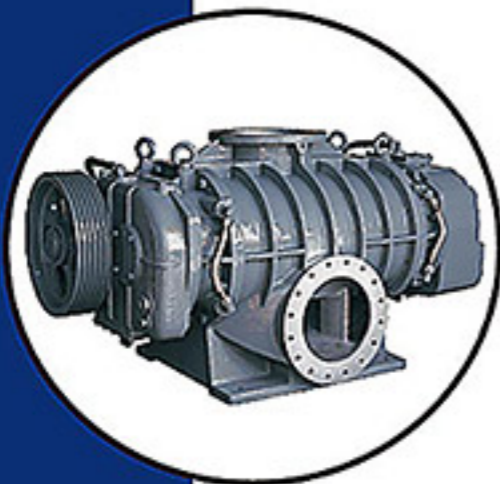

Three Lobes Roots Type Blower



Longtech Soundproof Enclosure Package



LONGTECH

Longtech

Longtech has been designing and manufacturing superior industrial machinery since 1982 – with 30 years of experience developing high quality three lobe roots type blowers.

In this tough market, we strongly adhere to competitive prices, efficiency, sturdiness, innovation, durability and easy maintenance. We aim to preserve product stability and production standardization making sure we remain on par with other worldwide manufacturers.

Over the past years, we have thrived in the lead of the Taiwan and Asian markets, earning a great deal of worldwide credibility. Here, we manufacture and support the equipment and systems in Taiwan. We guaranty to offer our customer the best products and services. We believe that our reputation for reliability, excellent service and product quality has helped us grow into a global leader for blowers, enabling customer success

Longtech Machinery Industry Co., Ltd.



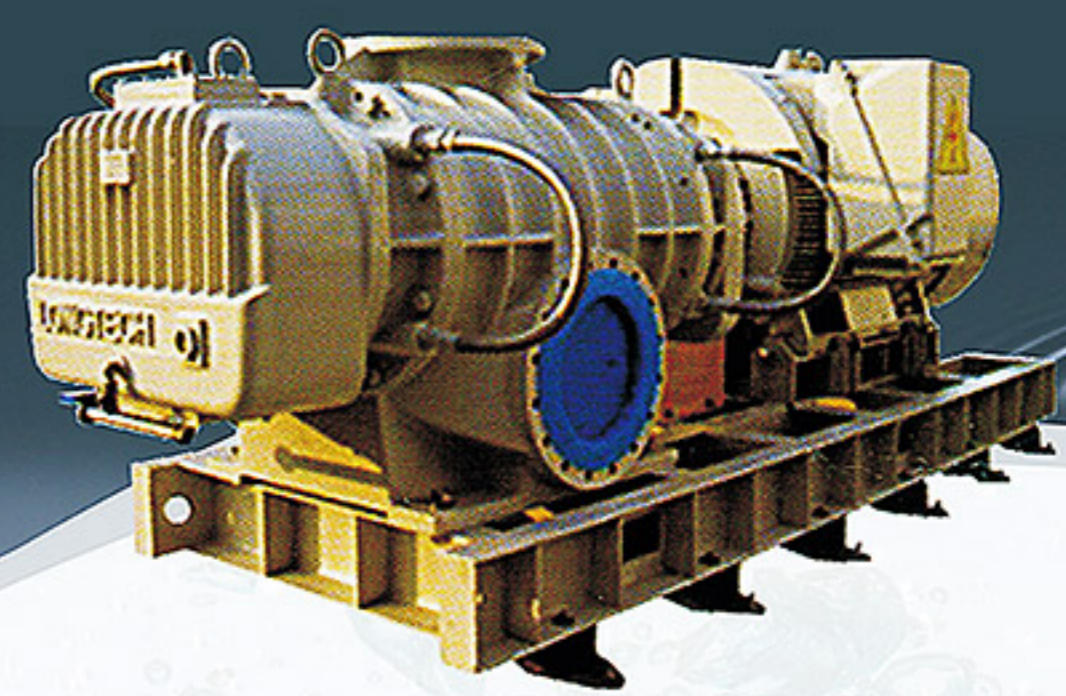

ROOTS TYPE BLOWER
LONGTECH

CONTENTS

- Blower Design and Technical Features 3 - 6
- Blower Package 7
- How to Use Performance Chart..... 8
- Pressure Performance Specification..... 9 - 13
- Vacuum Performance Specification.....14 - 18
- Noise Performance Specification19 - 20
- Structure and Material21
- Dimensions and Weight 22 - 24
- Accessories25 - 26



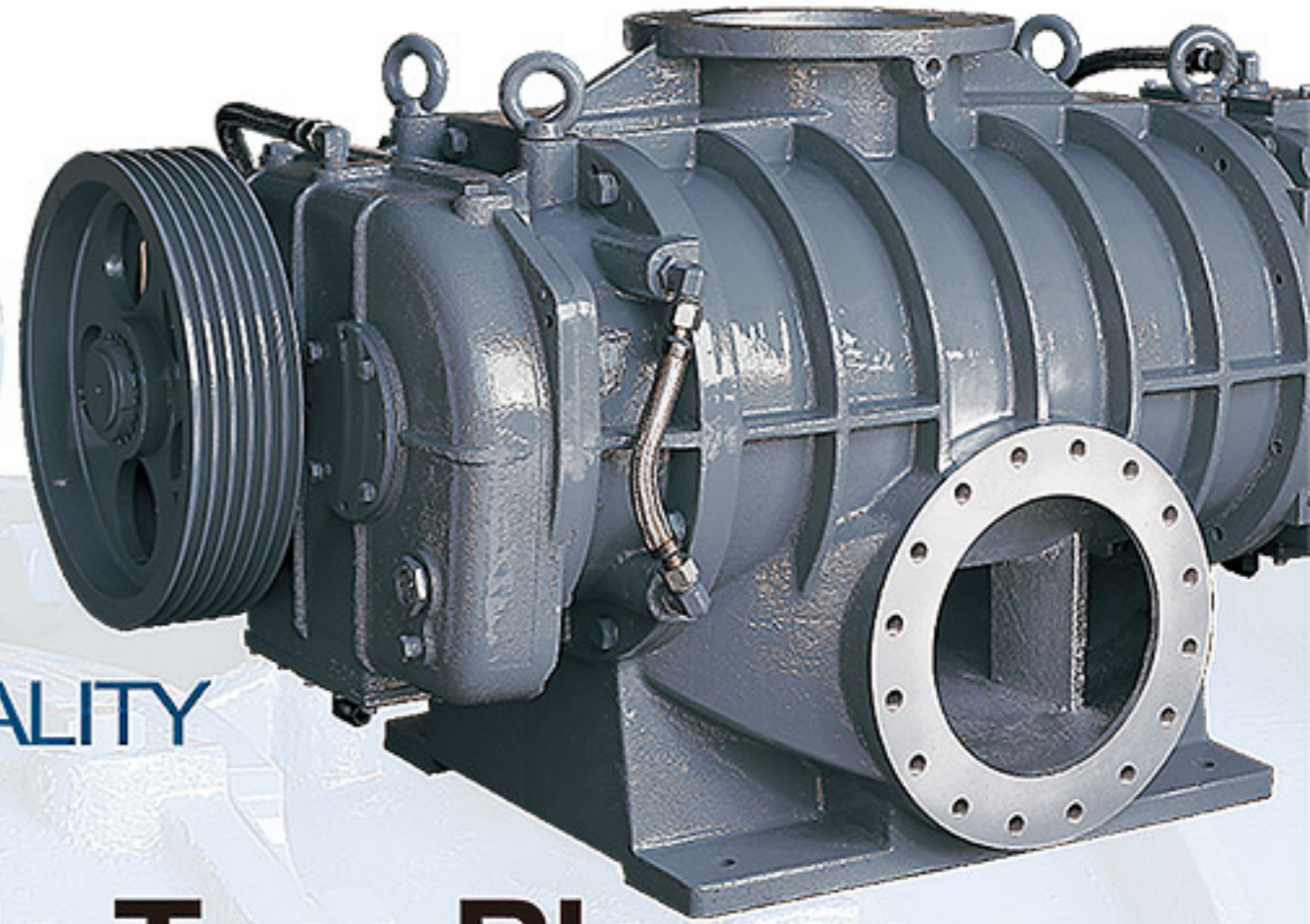

HIGH-PERFORMANCE QUALITY

Longtech Three Lobes Roots Type Blower

Advanced Blower Design

Longtech Roots-type Blower is the innovative positive displacement rotary blower with three-lobe, combined with CNC and 3D machine to make precise rotors, precision and durability throughout the manufacturing of our rotors, while also 20% longer bearing life and reducing the 5dB noise, energy consumption and vibrations.

Feature

- Stable air flow and fewer pressure variations
- Clean air; with no oil dirty particles
- Construction is simple and easy to maintain
- Bearings and gears are lubricated with oil on end side of the blower
- All of product can be used for OEM
- Proven design, backed by a 1-year warranty.

EXCEPTIONAL ENGINEERING

Quality Manufacture

Seal:

Low-wear, non-contacting, labyrinth-type seals ensure performance and long life.

Casing:

All Longtech blower units are single-piece construction and precision machined cast iron, with ribs for strength and consistent thermal behavior.

Shafts:

Impeller shafts are alloy steel forgings that allow higher operating pressures and rotation speeds.

Bearings:

All Longtech blower units are using SKF / NTA bearings with long life, Anti-friction type vary with machine.

Rotors:

Made from cast iron or stainless steel with stiff design for maximum life.
By CNC and 3D machinery control to ensure the highest performances, providing with trouble-free performance and durability.

Timing Gears:

Forged steel gears with hardened and ground spur teeth to reduced vibrations and ensures accurate rotor to rotor timing fo smooth and efficient operation.

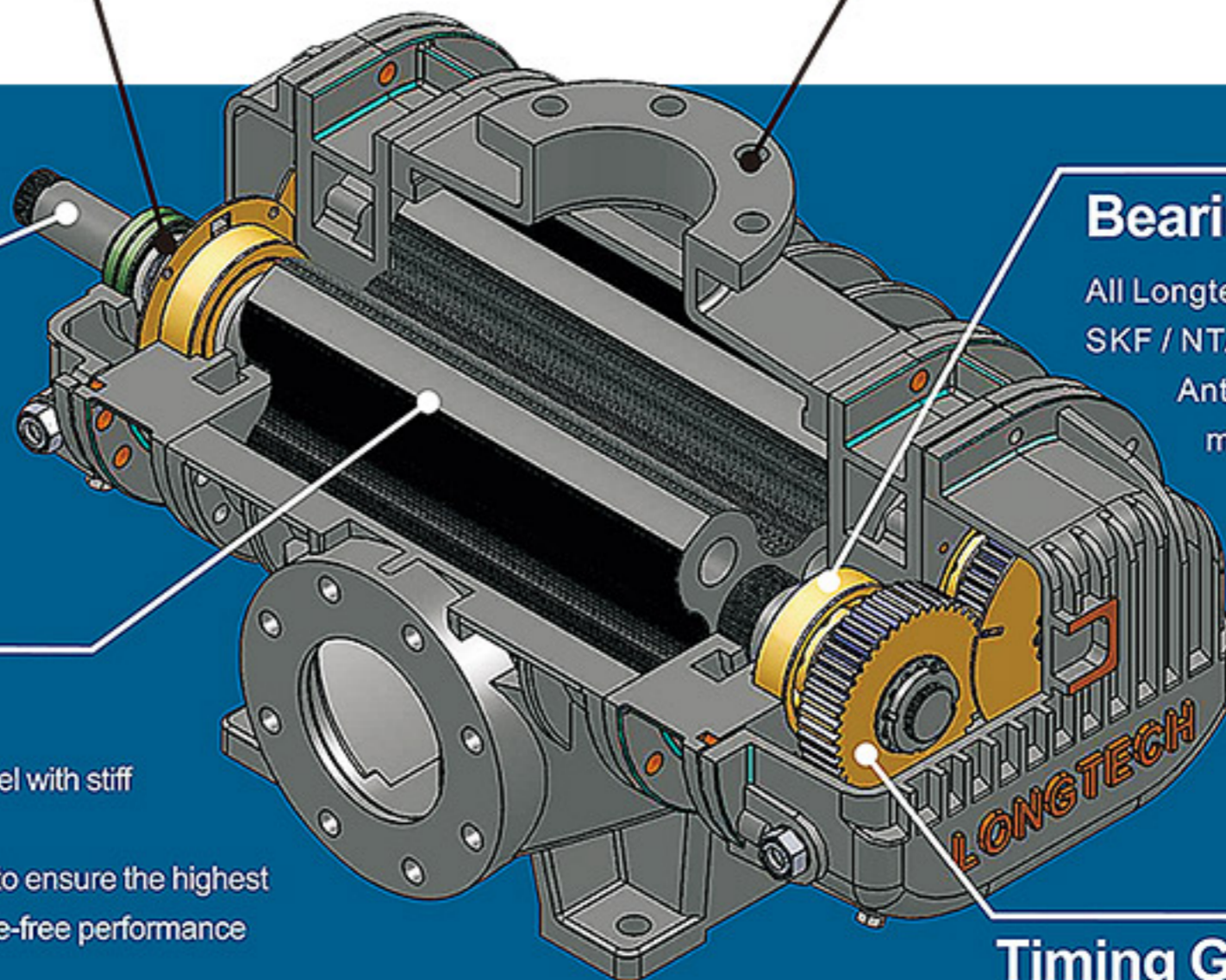

Inquiry

- ▣ Longtech develops positive displacement rotary blower for a full range of application.
- ▣ When enquiring, please inform us of the following:
 - Applications: water aeration, pneumatic conveying etc
 - Specifications: suction capacity, pressure, temperature and humidity
 - Drive: motor type and condition
 - Installation: indoor or outdoor, ambient temperature
 - Type of gas: name and properties

Longtech Blower Pressure Blower Complete Set

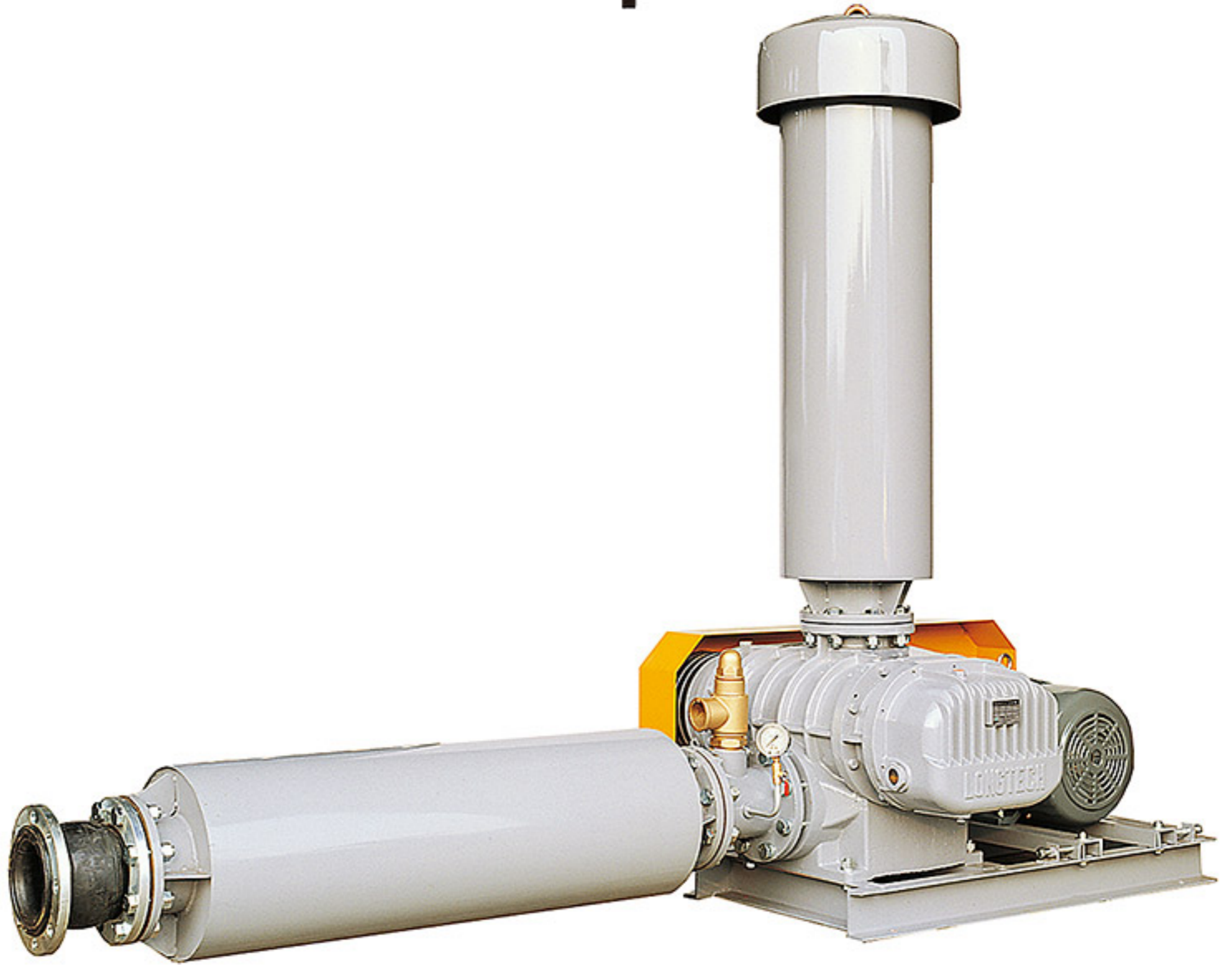

Type Model

LT-040
 LT-050
 LT-065
 LT-080
 LT-100
 LT-125S
 LT-125
 LT-150
 LT-200
 LT-200A
 LT-250
 LT-250A
 LT-300
 LT-300A
 LT-350
 LT-400

Advantage

Wider range for volume ,pressure and Horse power.

- Bore 40mm to 400mm (1.5" to 16")
- Pressure: 1000 to 8000 mmAq (Air cooled)
8000 to 10000 mmAq (Water cooled and the type model is LT - #W)
- Horse power : 0.5 to 700 Hp
- Capacity: 0.5 to 360 m³/min

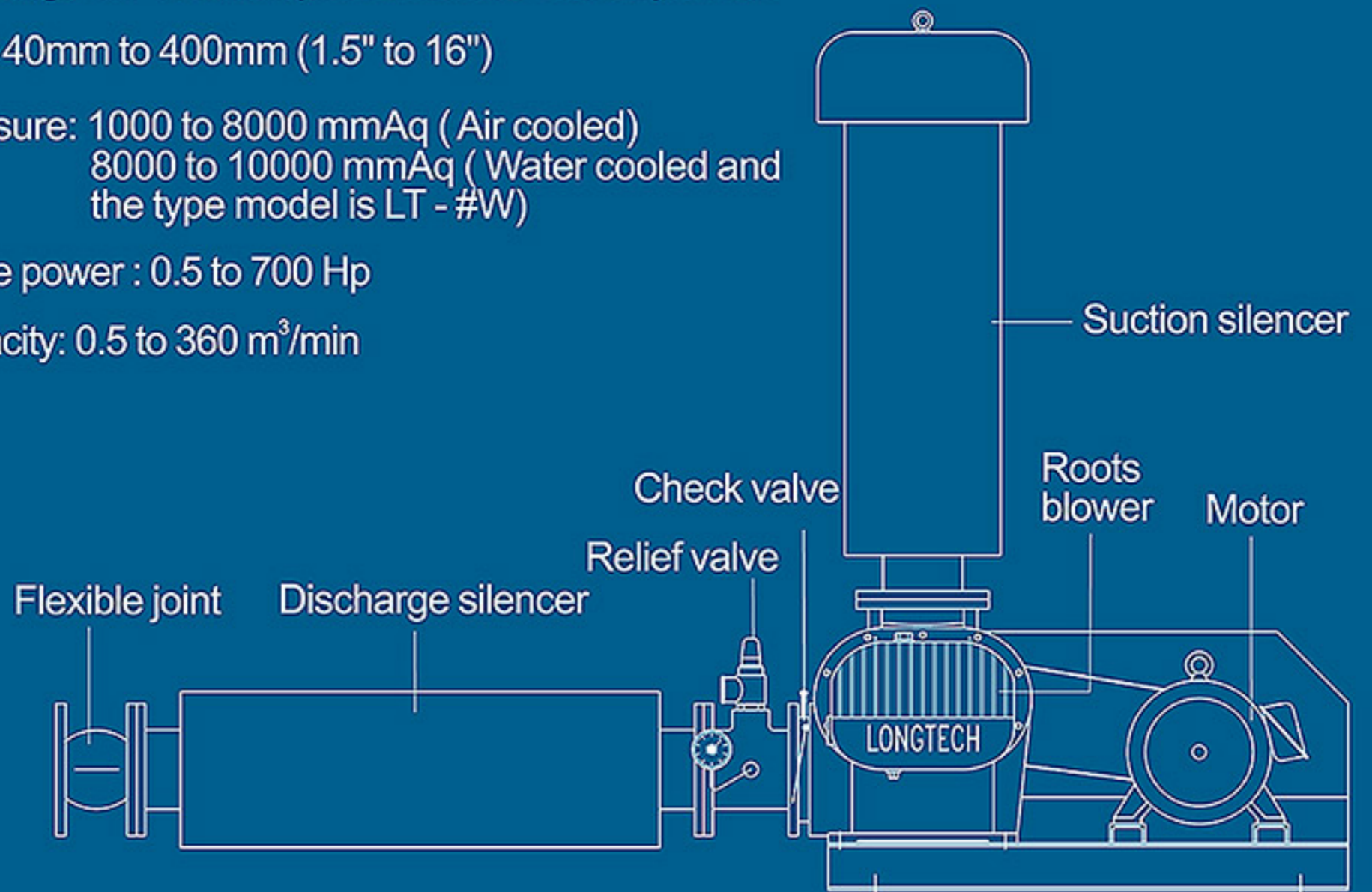



Longtech Blower Vacuum Pump Complete Set

Advantage

Wider range for volume ,vacuum and Horse power.

- Bore 40mm to 400mm (1.5" to 16")
- Vacuum : -1000 to - 5000 mmAq
- Horse power : 0.5 to 700 Hp
- Capacity: 0.5 to 360 m³/min

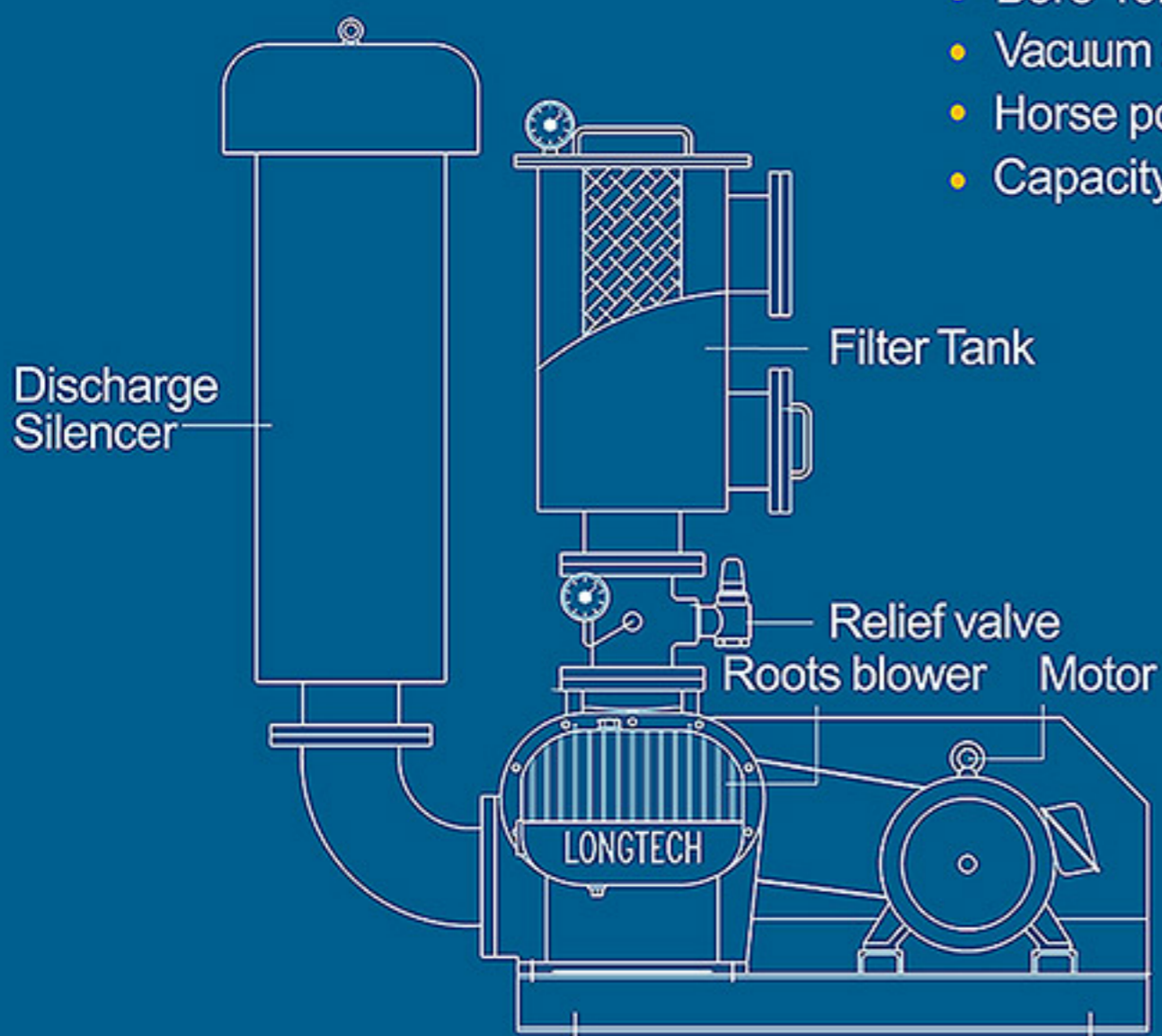

Type Model

LTV-040
 LTV-050
 LTV-065
 LTV-080
 LTV-100
 LTV-125S
 LTV-125
 LTV-150
 LTV-200
 LTV-200A
 LTV-250
 LTV-250A
 LTV-300
 LTV-300A
 LTV-350
 LTV-400

SIMPLE TO OPERATE AND REDUCE NOISE

Soundproof Enclosures Package

In addition to our proven quality on roots blower manufacture, LONGTECH also designs (ODM) high efficiency soundproof enclosures, to solve your noise problem.

Each case is specifically manufactured according to your requirements with LT blower package.

Flange Standard: Japan Standard
(It can be adapted to your requirements.)

Features Include:

- Independent frame system
- Modular acoustic panels
- Reduce noise
- Designed and built for your application
- Guarantee 8 to 15 Db noise reduction (depending on the project)
- Service gate
- Temperature and pressure gauge
- Air inlet and fan covers
- Box base (optional)

Enclosure Material

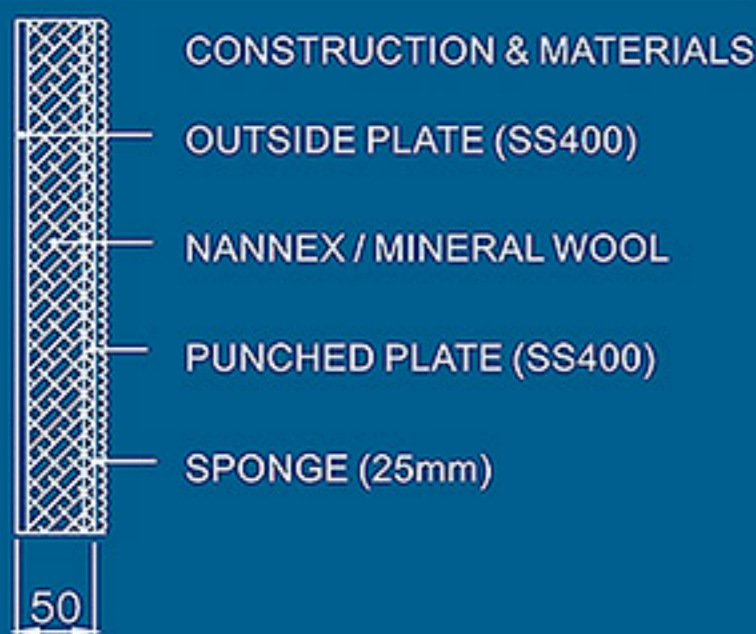

How to Use Performance Chart



1. Air volume is general shown in term of:

(1) Stand state (Qs):

At 20°C, 10332 mmAq and RH. 65%

(2) Normal state (Qn):

At 0°C, 10332 mmAq and RH. 0%

2. Performance table shows the capacity is the standard suction state.

3. Performance table shows the pressure is the static pressure.

4. Volume conversion formula:

■ Q_1 (m³/min) : Air volume in P_1 (mmAq), T_1 (°K).

■ Q_2 (m³/min) : Air volume in P_2 (mmAq), T_2 (°K).

$$Q_2 = Q_1 \cdot \frac{P_1}{P_2} \cdot \frac{T_2}{T_1}$$

5. Pressure conversion formula

(1) For pressure:

$$Ps = \left(\frac{10332 + P_2}{10332 + P_1} - 1 \right) \cdot 10332$$

(2) For vacuum:

$$Ps = \left(\frac{10332 + P_1}{10332 + P_2} - 1 \right) \cdot 10332$$

P_1 : Suction static pressure

P_2 : Discharge static pressure

Ps: static pressure in catalog

6. Example Operating specification:

■ Air volume	5.16 m ³ /min
■ Suction static pressure	-500 mmAq
■ Discharge static pressure	+4260 mmAq
■ Suction temperature	40 °c

CHOICE :

Air volume (5.16 m³/min) converts to STP state

$$Q = 5.16 \cdot \frac{10332 - 500}{10332} \cdot \frac{273 + 20}{273 + 40} = 4.60 \text{ m}^3/\text{min}$$

Static pressure changed to:

$$PS = \left(\frac{10332 + 4260}{10332 - 500} - 1 \right) \cdot 10332 = 5000 \text{ mmAq}$$

You can find the LT-080 with 1300RPM and 10HP can fits the specification at the performance table.

7. As the selection covers two models, you can select the small models with economic or the large models with lower noise and lower RPM.

Please refer the noise performance specification.

UNITS CONVERSION

PRESSURE

	mbar	Pa	atm	lbf/in ²	kgf/cm ²	in-Hg	mmAq
1 mbar	1	10 ²	9.869x10 ⁻⁴	1.45x10 ⁻²	1.02x10 ⁻³	2.953x10 ⁻²	10.197
1 Pa	0.01	1	9.869x10 ⁻⁶	1.45x10 ⁻⁴	1.02x10 ⁻⁵	2.953x10 ⁻⁴	0.102
1 atm	1.013x10 ³	1.013x10 ⁵	1	14.7	1.033	29.92	1.033x10 ⁴
1 lbf/in ²	68.95	6.895x10 ²	6.805x10 ⁻²	1	7.03x10 ⁻²	2.036	7.03x10 ²
1 kgf/cm ²	9.807x10 ²	9.807x10 ⁴	0.968	14.22	1	28.96	10 ⁴
1 in-Hg	33.86	3.386x10 ³	3.342x10 ⁻²	0.491	3.45x10 ⁻²	1	3.45x10 ²
1 mmAq	9.807x10 ⁻²	9.807	9.677x10 ⁻⁵	1.42x10 ⁻³	10 ⁻⁴	2.896x10 ⁻³	1

CAPACITY

	m ³ /min	m ³ /hr	l/min	ft ³ /min
1 m ³ /min	1	60	1000	35.31
1 m ³ /hr	0.017	1	16.67	0.589
1 l/min	0.001	0.06	1	0.035
1 ft ³ /min	0.028	1.699	28.32	1

POWER

	kg-m/sec	kW	HP	PS
1 kg-m/sec	1	0.01	0.013	0.013
1 kW	101.97	1	1.341	1.360
1 HP	76.038	0.746	1	1.014
1 PS	75	0.736	0.986	1

Pressure Performance Table

TYPE	RPM	Qs(m ³ /min)				PRESSURE(mmAq)								La(Kw)			
		1000mmAq		2000mmAq		3000mmAq		4000mmAq		5000mmAq		6000mmAq		7000mmAq		8000mmAq	
		Qs	La	Qs	La	Qs	La	Qs	La	Qs	La	Qs	La	Qs	La	Qs	La
LT-040	1650	0.60	0.19	0.57	0.37	0.54	0.53	0.51	0.67	0.49	0.81	0.48	0.94				
	1800	0.68	0.21	0.64	0.40	0.61	0.57	0.59	0.74	0.57	0.88	0.55	1.02				
	1950	0.75	0.23	0.71	0.43	0.69	0.62	0.66	0.80	0.64	0.96	0.62	1.11				
	2100	0.83	0.24	0.79	0.47	0.76	0.67	0.74	0.86	0.71	1.03	0.70	1.19				
	2250	0.90	0.26	0.86	0.50	0.84	0.72	0.81	0.92	0.79	1.11	0.77	1.28				
	2400	0.97	0.28	0.94	0.53	0.91	0.77	0.88	0.98	0.86	1.18	0.85	1.36				
	2550	1.05	0.30	1.01	0.57	0.98	0.81	0.96	1.04	0.94	1.25	0.92	1.45				
LT-050	850	0.99	0.41	0.79	0.80	0.64	1.16	0.50	1.51	0.38	1.84	0.29	2.15	0.21	2.45	0.15	2.74
	1000	1.31	0.48	1.11	0.94	0.96	1.37	0.82	1.77	0.70	2.16	0.61	2.53	0.53	2.88	0.47	3.22
	1150	1.63	0.56	1.44	1.08	1.28	1.57	1.15	2.04	1.02	2.49	0.93	2.91	0.86	3.32	0.79	3.71
	1300	1.95	0.63	1.76	1.22	1.61	1.78	1.47	2.31	1.34	2.81	1.25	3.29	1.18	3.75	1.12	4.19
	1450	2.27	0.70	2.08	1.36	1.93	1.98	1.79	2.57	1.67	3.13	1.58	3.67	1.50	4.18	1.44	4.67
	1600	2.60	0.77	2.40	1.50	2.25	2.19	2.11	2.84	1.99	3.46	1.90	4.05	1.82	4.61	1.76	5.16
	1750	2.92	0.85	2.72	1.64	2.57	2.39	2.43	3.11	2.31	3.78	2.22	4.43	2.14	5.05	2.08	5.64
LT-065	850	2.07	0.62	1.89	1.21	1.71	1.76	1.55	2.29	1.41	2.78	1.29	3.26	1.19	3.71	1.09	4.15
	1000	2.58	0.73	2.41	1.42	2.22	2.07	2.07	2.69	1.93	3.27	1.81	3.83	1.71	4.37	1.60	4.88
	1150	3.10	0.84	2.93	1.64	2.74	2.38	2.58	3.09	2.45	3.77	2.33	4.41	2.22	5.03	2.12	5.62
	1300	3.62	0.95	3.45	1.85	3.26	2.69	3.10	3.50	2.96	4.26	2.84	4.99	2.74	5.68	2.64	6.35
	1450	4.13	1.06	3.96	2.06	3.77	3.01	3.62	3.90	3.48	4.75	3.36	5.56	3.26	6.34	3.15	7.08
	1600	4.65	1.17	4.48	2.28	4.29	3.32	4.13	4.30	4.00	5.24	3.88	6.14	3.77	6.99	3.67	7.81
	1750	5.17	1.28	5.00	2.49	4.81	3.63	4.65	4.71	4.51	5.73	4.39	6.71	4.29	7.65	4.19	8.55
LT-080	850	3.24	1.12	2.87	2.14	2.54	3.08	2.23	3.94	1.95	4.73	1.70	5.47	1.48	6.15	1.28	6.79
	1000	4.14	1.32	3.77	2.52	3.44	3.62	3.13	4.63	2.85	5.57	2.60	6.44	2.38	7.24	2.18	7.99
	1150	5.04	1.51	4.67	2.90	4.34	4.16	4.03	5.33	3.75	6.40	3.50	7.40	3.28	8.33	3.08	9.19
	1300	5.94	1.71	5.57	3.27	5.24	4.71	4.93	6.02	4.65	7.24	4.40	8.37	4.18	9.41	3.98	10.39
	1450	6.84	1.91	6.47	3.65	6.14	5.25	5.83	6.72	5.55	8.07	5.30	9.33	5.08	10.50	4.88	11.58
	1600	7.74	2.11	7.37	4.03	7.04	5.79	6.73	7.41	6.45	8.91	6.20	10.30	5.98	11.58	5.78	12.78
	1750	8.64	2.30	8.27	4.41	7.94	6.33	7.63	8.11	7.35	9.75	7.10	11.26	6.88	12.67	6.68	13.98
LT-100	850	5.80	1.57	5.19	3.00	4.65	4.31	4.16	5.51	3.74	6.63	3.36	7.66	3.03	8.62	2.74	9.51
	1000	7.06	1.84	6.45	3.53	5.91	5.07	5.42	6.49	5.00	7.80	4.62	9.01	4.29	10.14	4.00	11.19
	1150	8.32	2.12	7.71	4.05	7.17	5.83	6.68	7.46	6.26	8.97	5.88	10.36	5.55	11.66	5.26	12.86
	1300	9.58	2.40	8.97	4.58	8.43	6.59	7.94	8.43	7.52	10.14	7.14	11.71	6.81	13.18	6.52	14.54
	1450	10.84	2.67	10.23	5.11	9.69	7.35	9.20	9.41	8.78	11.31	8.40	13.06	8.07	14.70	7.78	16.22
	1600	12.10	2.95	11.49	5.64	10.95	8.11	10.46	10.38	10.04	12.47	9.66	14.42	9.33	16.22	9.04	17.90
	1750	13.36	3.23	12.75	6.17	12.21	8.87	11.72	11.35	11.30	13.64	10.92	15.77	10.59	17.74	10.30	19.57

Pressure Performance Table

TYPE	RPM	Qs(m ³ /min)				PRESSURE(mmAq)								La(Kw)			
		1000mmAq		2000mmAq		3000mmAq		4000mmAq		5000mmAq		6000mmAq		7000mmAq		8000mmAq	
		Qs	La	Qs	La	Qs	La	Qs	La	Qs	La	Qs	La	Qs	La	Qs	La
LT-125S	750	8.13	2.05	7.43	3.91	6.80	5.62	6.22	7.20	5.72	8.66	5.25	10.01	4.83	11.26	4.46	12.42
	900	10.02	2.46	9.32	4.70	8.69	6.75	8.11	8.64	7.61	10.39	7.14	12.01	6.72	13.51	6.35	14.91
	1050	11.91	2.86	11.21	5.48	10.58	7.87	10.00	10.08	9.50	12.12	9.03	14.01	8.61	15.76	8.24	17.39
	1200	13.80	3.27	13.10	6.26	12.47	9.00	11.89	11.52	11.39	13.85	10.92	16.01	10.50	18.01	10.13	19.88
	1350	15.69	3.68	14.99	7.04	14.36	10.12	13.78	12.96	13.28	15.58	12.81	18.01	12.39	20.27	12.02	22.36
	1500	17.58	4.09	16.88	7.83	16.25	11.25	15.67	14.40	15.17	17.31	14.70	20.01	14.28	22.52	13.91	24.85
	1650	19.47	4.50	18.77	8.61	18.14	12.37	17.56	15.84	17.06	19.04	16.59	22.01	16.17	24.77	15.80	27.33
LT-125	750	10.29	2.59	9.42	4.96	8.62	7.13	7.88	9.12	7.25	10.97	6.66	12.67	6.11	14.26	5.65	15.74
	900	12.69	3.11	11.81	5.95	11.01	8.55	10.28	10.95	9.64	13.16	9.05	15.21	8.51	17.11	8.04	18.89
	1050	15.08	3.63	14.20	6.94	13.41	9.98	12.67	12.77	12.03	15.35	11.44	17.74	10.90	19.97	10.44	22.04
	1200	17.48	4.15	16.60	7.93	15.80	11.40	15.07	14.59	14.43	17.55	13.84	20.28	13.29	22.82	12.83	25.18
	1350	19.87	4.66	18.99	8.92	18.19	12.83	17.46	16.42	16.82	19.74	16.23	22.81	15.69	25.67	15.23	28.33
	1500	22.26	5.18	21.39	9.91	20.59	14.25	19.85	18.24	19.22	21.93	18.63	25.35	18.08	28.52	17.62	31.48
	1650	24.66	5.70	23.78	10.90	22.98	15.68	22.25	20.07	21.61	24.13	21.02	27.88	20.48	31.38	20.01	34.63
LT-150	750	13.32	3.34	12.62	6.39	11.98	9.19	11.40	11.76	10.87	14.14	10.39	16.34	10.00	18.39	9.61	20.30
	900	16.40	4.01	15.70	7.67	15.06	11.03	14.49	14.11	13.95	16.97	13.48	19.61	13.09	22.07	12.70	24.36
	1050	19.49	4.68	18.79	8.95	18.15	12.86	17.58	16.47	17.04	19.80	16.57	22.88	16.18	25.75	15.78	28.41
	1200	22.58	5.35	21.88	10.23	21.24	14.70	20.66	18.82	20.13	22.62	19.65	26.15	19.26	29.42	18.87	32.47
	1350	25.66	6.02	24.96	11.50	24.33	16.54	23.75	21.17	23.21	25.45	22.74	29.42	22.35	33.10	21.96	36.53
	1500	28.75	6.68	28.05	12.78	27.41	18.38	26.84	23.52	26.30	28.28	25.83	32.69	25.44	36.78	25.05	40.59
	1650	31.84	7.35	31.14	14.06	30.50	20.21	29.92	25.88	29.39	31.11	28.91	35.96	28.52	40.46	28.13	44.65
LT-200	600	17.01	4.84	15.95	9.27	15.04	13.32	14.21	17.06	13.53	20.51	12.93	23.71	12.40	26.68	11.98	29.45
	750	22.68	6.05	21.62	11.58	20.71	16.65	19.88	21.32	19.20	25.64	18.60	29.64	18.07	33.36	17.65	36.82
	900	28.35	7.27	27.29	13.90	26.38	19.98	25.55	25.59	24.87	30.77	24.27	35.57	23.74	40.03	23.32	44.18
	1050	34.02	8.48	32.96	16.22	32.05	23.32	31.22	29.85	30.54	35.89	29.94	41.49	29.41	46.70	28.99	51.55
	1200	39.69	9.69	38.63	18.53	37.72	26.65	36.89	34.12	36.21	41.02	35.61	47.42	35.08	53.37	34.66	58.91
	1350	45.36	10.90	44.30	20.85	43.39	29.98	42.56	38.38	41.88	46.15	41.28	53.35	40.75	60.04	40.33	66.27
	1500	51.03	12.11	49.97	23.17	49.06	33.31	48.23	42.65	47.55	51.28	46.95	59.28	46.42	66.71	46.00	73.64
LT-200A	600	27.72	7.40	26.22	14.16	24.89	20.35	23.68	26.06	22.58	31.34	21.60	36.23	20.73	40.77	19.98	45.00
	750	36.38	9.25	34.88	17.70	33.55	25.44	32.34	32.58	31.24	39.17	30.26	45.28	29.39	50.96	28.64	56.25
	900	45.05	11.10	43.54	21.24	42.22	30.53	41.00	39.09	39.91	47.01	38.92	54.34	38.06	61.15	37.31	67.50
	1050	53.71	12.95	52.21	24.77	50.88	35.62	49.67	45.61	48.57	54.84	47.59	63.39	46.72	71.34	45.97	78.75
	1200	62.37	14.80	60.87	28.31	59.54	40.71	58.33	52.12	57.23	62.67	56.25	72.45	55.38	81.54	54.63	90.00
	1350	71.03	16.65	69.53	31.85	68.20	45.80	66.99	58.64	65.89	70.51	64.91	81.51	64.04	91.73	63.29	101.2
	1500	79.70	18.50	78.19	35.39	76.87	50.89	75.65	65.16	74.56	78.34	73.57	90.56	72.71	101.9	71.96	112.5

Pressure Performance Table

TYPE	RPM	Qs(m ³ /min)				PRESSURE(mmAq)								La(Kw)			
		1000mmAq		2000mmAq		3000mmAq		4000mmAq		5000mmAq		6000mmAq		7000mmAq		8000mmAq	
		Qs	La	Qs	La	Qs	La	Qs	La	Qs	La	Qs	La	Qs	La	Qs	La
LT-250	600	27.72	7.40	26.22	14.16	24.89	20.35	23.68	26.06	22.58	31.34	21.60	36.23	20.73	40.77	19.98	45.00
	750	36.38	9.25	34.88	17.70	33.55	25.44	32.34	32.58	31.24	39.17	30.26	45.28	29.39	50.96	28.64	56.25
	900	45.05	11.10	43.54	21.24	42.22	30.53	41.00	39.09	39.91	47.01	38.92	54.34	38.06	61.15	37.31	67.50
	1050	53.71	12.95	52.21	24.77	50.88	35.62	49.67	45.61	48.57	54.84	47.59	63.39	46.72	71.34	45.97	78.75
	1200	62.37	14.80	60.87	28.31	59.54	40.71	58.33	52.12	57.23	62.67	56.25	72.45	55.38	81.54	54.63	90.00
	1350	71.03	16.65	69.53	31.85	68.20	45.80	66.99	58.64	65.89	70.51	64.91	81.51	64.04	91.73	63.29	101.2
	1500	79.70	18.50	78.19	35.39	76.87	50.89	75.65	65.16	74.56	78.34	73.57	90.56	72.71	101.9	71.96	112.5
LT-250A	600	39.45	10.36	37.54	18.02	35.93	25.92	34.56	33.71	33.33	41.48	32.19	49.20	31.19	56.8	30.35	64.3
	750	50.92	12.95	49.00	22.52	47.40	32.40	46.02	42.14	44.80	51.85	43.65	61.50	42.66	71.0	41.82	80.4
	900	62.38	15.53	60.47	27.03	58.87	38.88	57.49	50.57	56.27	62.22	55.12	73.80	54.13	85.2	53.29	96.5
	1050	73.85	18.12	71.94	31.53	70.33	45.36	68.96	58.99	67.73	72.59	66.59	86.10	65.59	99.4	64.75	112.6
	1200	85.32	20.71	83.41	36.04	81.80	51.84	80.43	67.42	79.20	82.96	78.06	98.39	77.06	113.6	76.22	128.7
	1350	96.79	23.30	94.87	40.54	93.27	58.32	91.89	75.85	90.67	93.33	89.52	110.7	88.53	127.8	87.69	144.7
	1500	108.3	25.89	106.3	45.05	104.7	64.80	103.4	84.28	102.1	103.7	101.0	123.0	100.0	142.0	99.16	160.8
LT-300	600	58.94	14.44	55.49	25.88	53.71	37.23	52.04	47.70	50.48	58.83	49.26	68.88	47.59	79.49	46.70	88.83
	750	75.62	18.06	72.17	32.35	70.39	46.54	68.72	59.63	67.16	73.53	65.94	86.10	64.27	99.36	63.38	111.0
	900	92.30	21.67	88.85	38.82	87.07	55.85	85.40	71.55	83.84	88.24	82.62	103.3	80.95	119.2	80.06	133.3
	1050	109.0	25.28	105.5	45.29	103.7	65.16	102.1	83.48	100.5	102.9	99.30	120.5	97.63	139.1	96.74	155.5
	1200	125.7	28.89	122.2	51.76	120.4	74.46	118.8	95.41	117.2	117.7	116.0	137.8	114.3	159.0	113.4	177.7
	1350	142.3	32.50	138.9	58.23	137.1	83.77	135.4	107.3	133.9	132.4	132.7	155.0	131.0	178.8	130.1	199.9
	1500	159.0	36.11	155.6	64.70	153.8	93.08	152.1	119.3	150.6	147.1	149.3	172.2	147.7	198.7	146.8	222.1
LT-300A	600	88.3	21.07	85.0	37.30	82.3	53.64	80.0	71.4	78.1	87.0	76.1	103.1	74.5	119.0	72.5	136.5
	700	104.7	24.58	101.4	43.52	98.7	62.58	96.4	83.3	94.5	101.5	92.5	120.3	90.9	138.9	88.9	159.3
	800	121.1	28.10	117.8	49.74	115.1	71.52	112.8	95.2	110.9	116.0	108.9	137.5	107.3	158.7	105.3	182.1
	900	137.5	31.61	134.2	55.95	131.5	80.46	129.2	107.1	127.3	130.5	125.3	154.7	123.7	178.6	121.7	204.8
	1000	153.9	35.12	150.6	62.17	147.9	89.39	145.6	119.0	143.7	145.0	141.7	171.9	140.1	198.4	138.1	227.6
	1100	170.3	38.63	167.0	68.39	164.3	98.33	162.0	130.9	160.1	159.5	158.1	189.1	156.5	218.2	154.5	250.3
	1200	186.7	42.15	183.4	74.60	180.7	107.3	178.4	142.8	176.5	174.0	174.5	206.3	172.9	238.1	170.9	273.1
LT-350	600	138.3	32.31	133.1	58.00	129.0	83.48	125.2	109.6	121.9	134.1	119.1	160.3	116.3	182.7	113.5	212.3
	700	163.8	37.70	158.6	67.67	154.5	97.39	150.7	127.9	147.4	156.4	144.6	187.1	141.8	213.2	139.0	247.7
	800	189.3	43.08	184.1	77.33	180.0	111.3	176.2	146.2	172.9	178.8	170.1	213.8	167.3	243.7	164.5	283.1
	900	214.8	48.47	209.6	87.00	205.5	125.2	201.7	164.5	198.4	201.1	195.6	240.5	192.8	274.1	190.0	318.5
	1000	240.3	53.85	235.1	96.67	231.0	139.1	227.2	182.7	223.9	223.4	221.1	267.2	218.3	304.6	215.5	353.9
	1100	265.8	59.24	260.6	106.3	256.5	153.0	252.7	201.0	249.4	245.8	246.6	294.0	243.8	335.0	241.0	389.2
	1200	291.3	64.62	286.1	116.0	282.0	167.0	278.2	219.3	274.9	268.1	272.1	320.7	269.3	365.5	266.5	424.6
LT-400	600	236.3	53.28	230.3	95.65	225.5	137.7	221.3	180.8	217.6	221.1	214.1	264.4	211.3	301.4	208.8	350.1
	650	257.4	57.73	251.4	103.6	246.5	149.1	242.3	195.9	238.6	239.5	235.2	286.5	232.3	326.5	229.8	379.3
	700	278.4	62.17	272.4	111.6	267.5	160.6	263.3	210.9	259.6	257.9	256.2	308.5	253.4	351.6	250.8	408.5
	750	299.4	66.61	293.4	119.6	288.6	172.1	284.4	226.0	280.7	276.4	277.2	330.5	274.4	376.7	271.9	437.7
	800	320.4	71.05	314.4	127.5	309.6	183.6	305.4	241.1	301.7	294.8	298.2	352.6	295.4	401.8	292.9	466.8
	850	341.5	75.49	335.5	135.5	330.6	195.0	326.4	256.1	322.7	313.2	319.3	374.6	316.4	426.9	313.9	496.0
	900	362.5	79.93	356.5	143.5	351.6	206.5	347.4	271.2	343.7	331.6	340.3	396.7	337.5	452.0	335.0	525.2

Pressure Performance Curve

LT-040

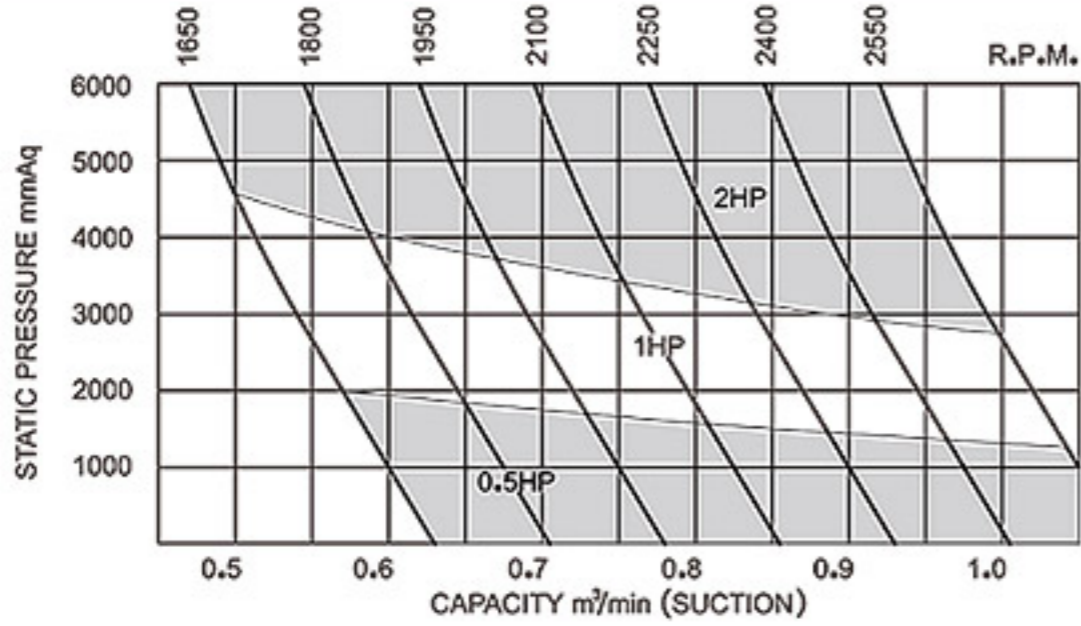

LT-100

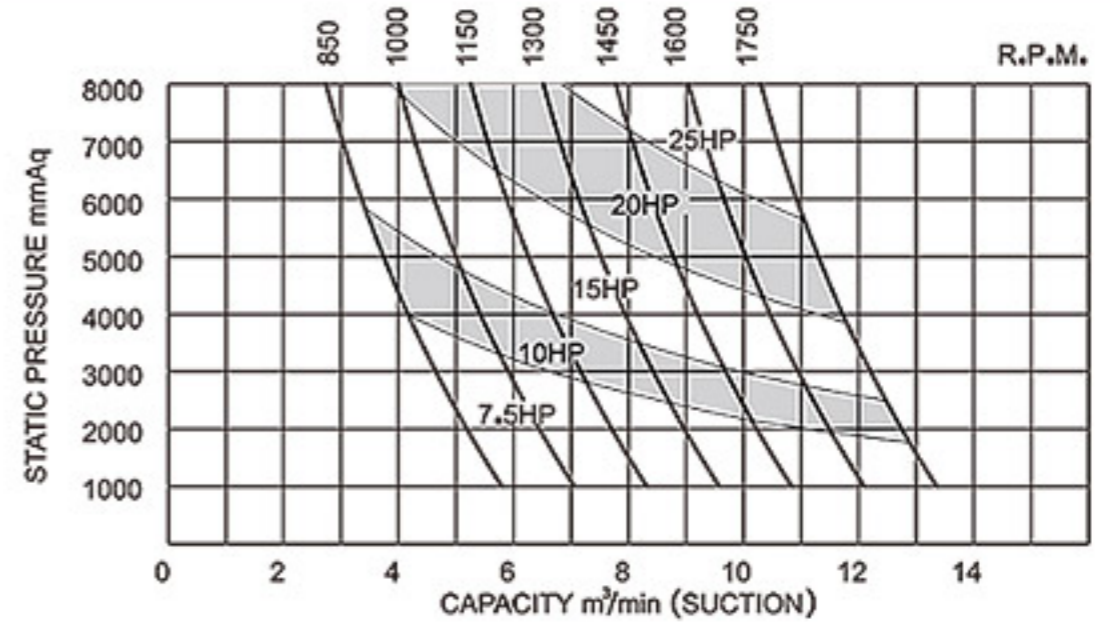

LT-050

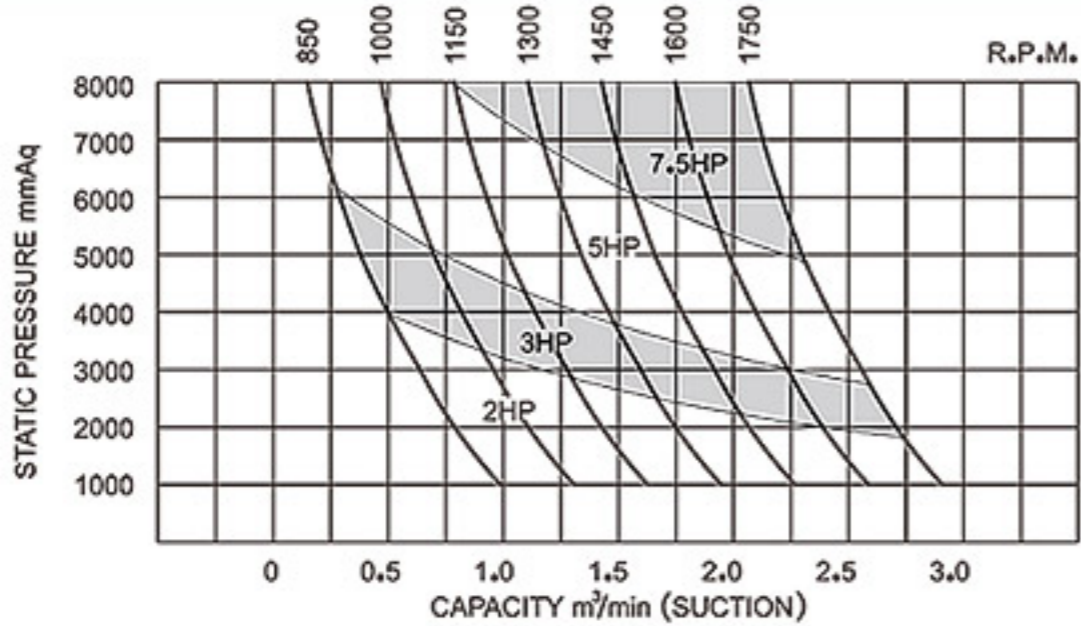

LT-125S

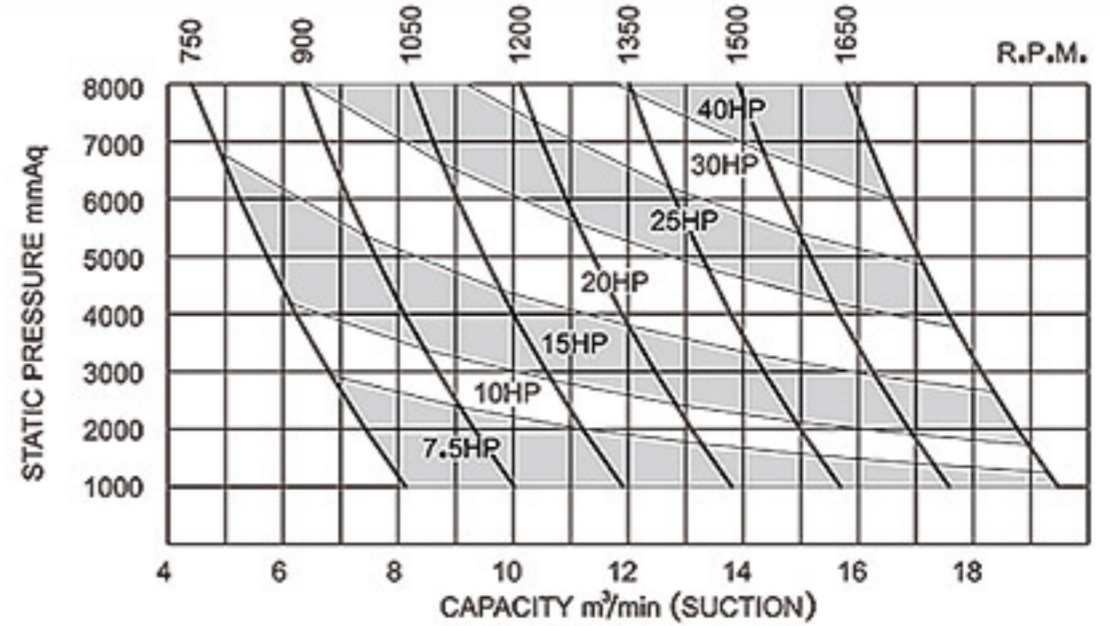

LT-065

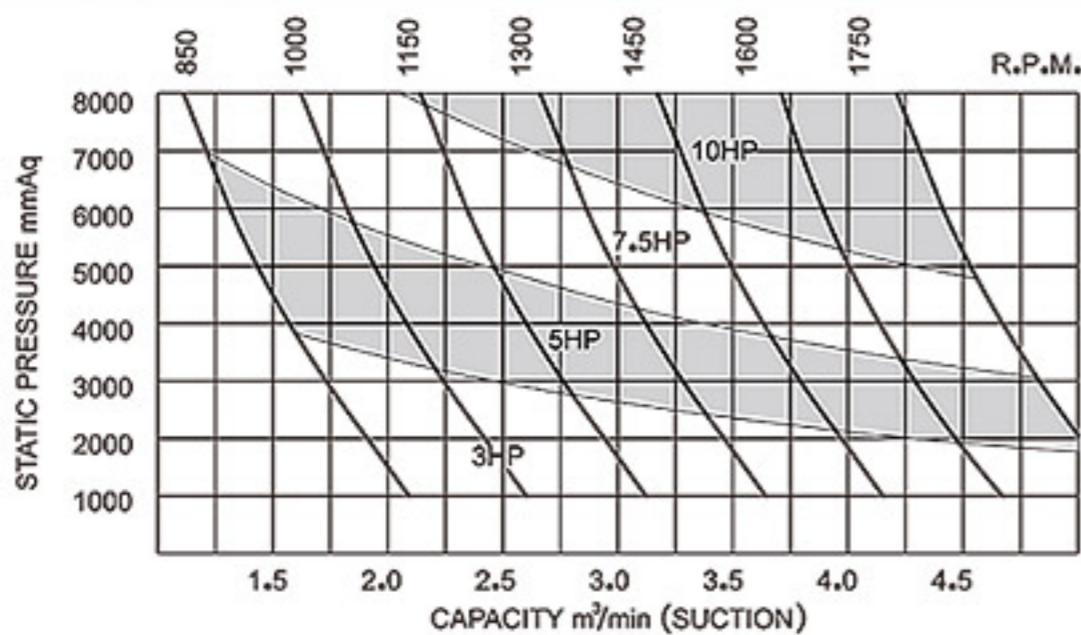

LT-125

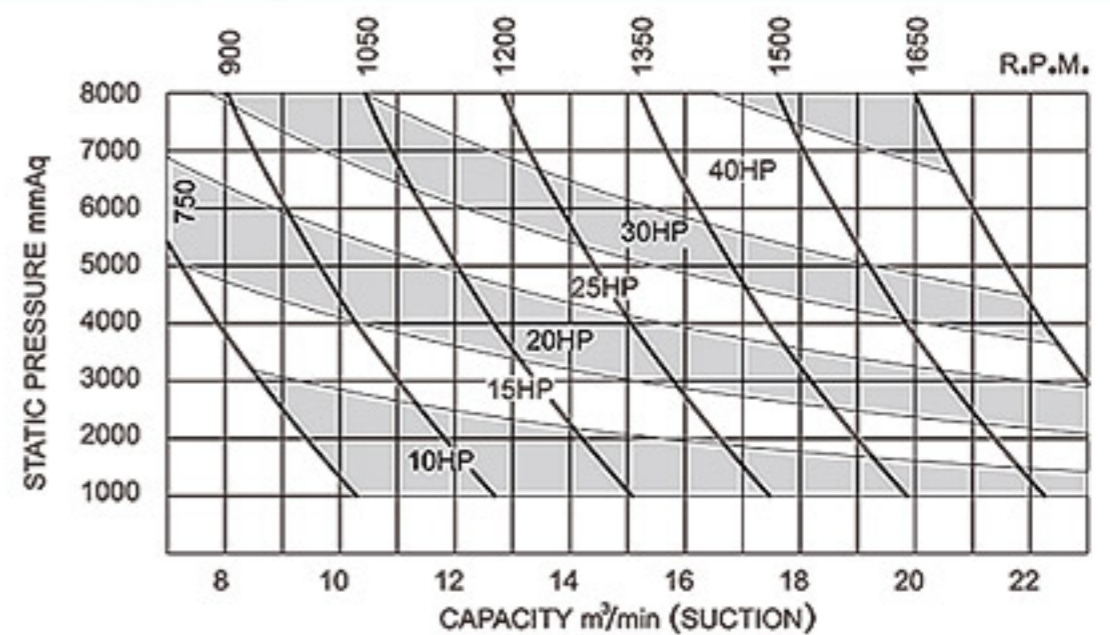

LT-080

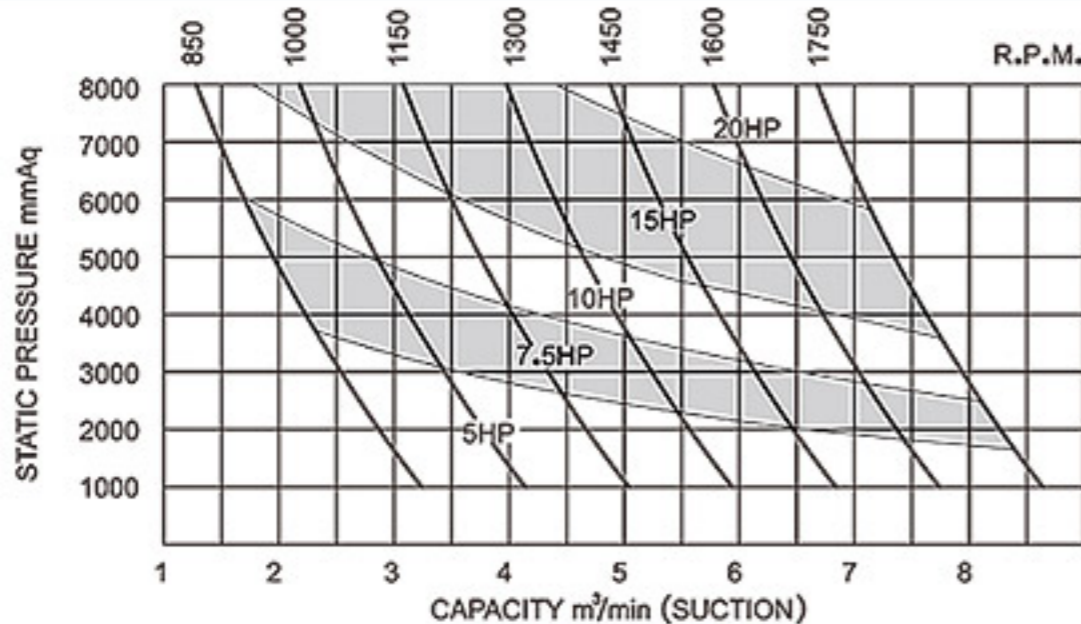

LT-150

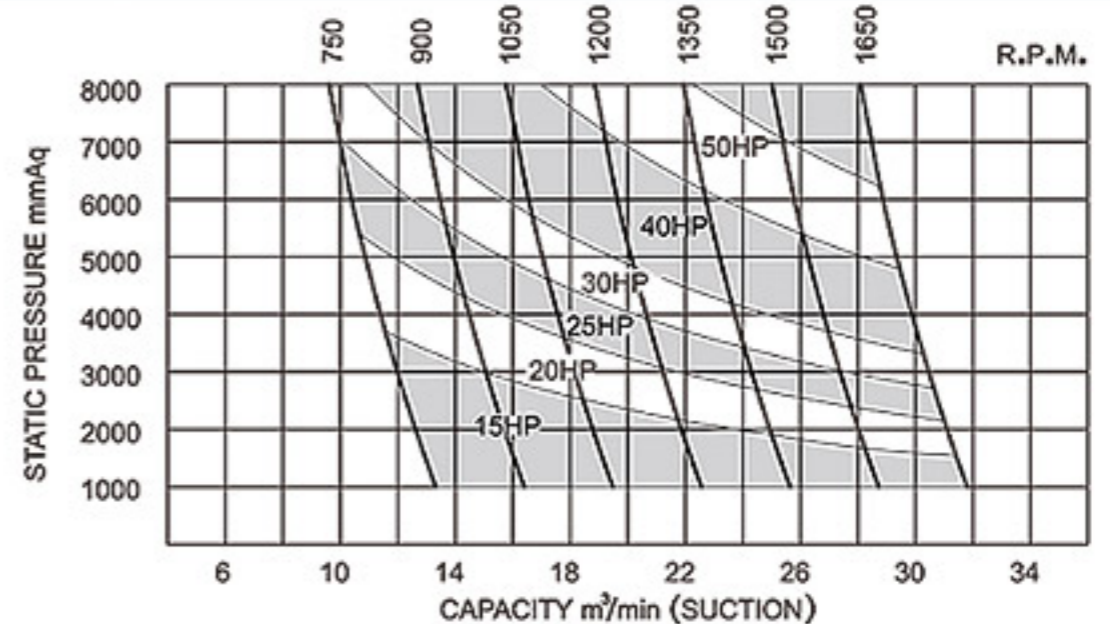

Pressure Performance Curve

LT-200

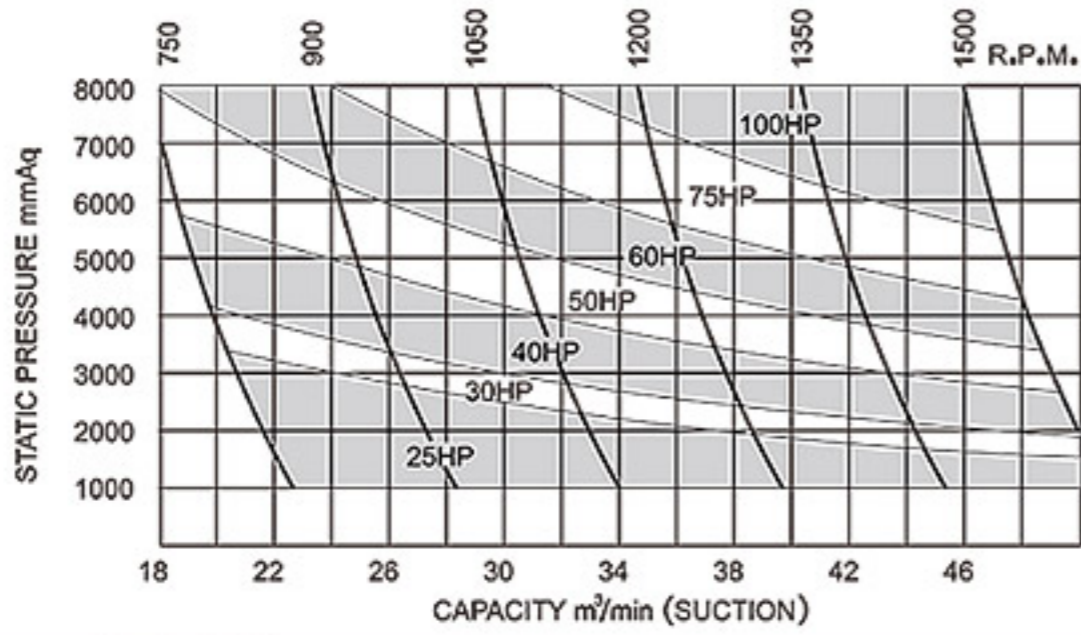

LT-200A

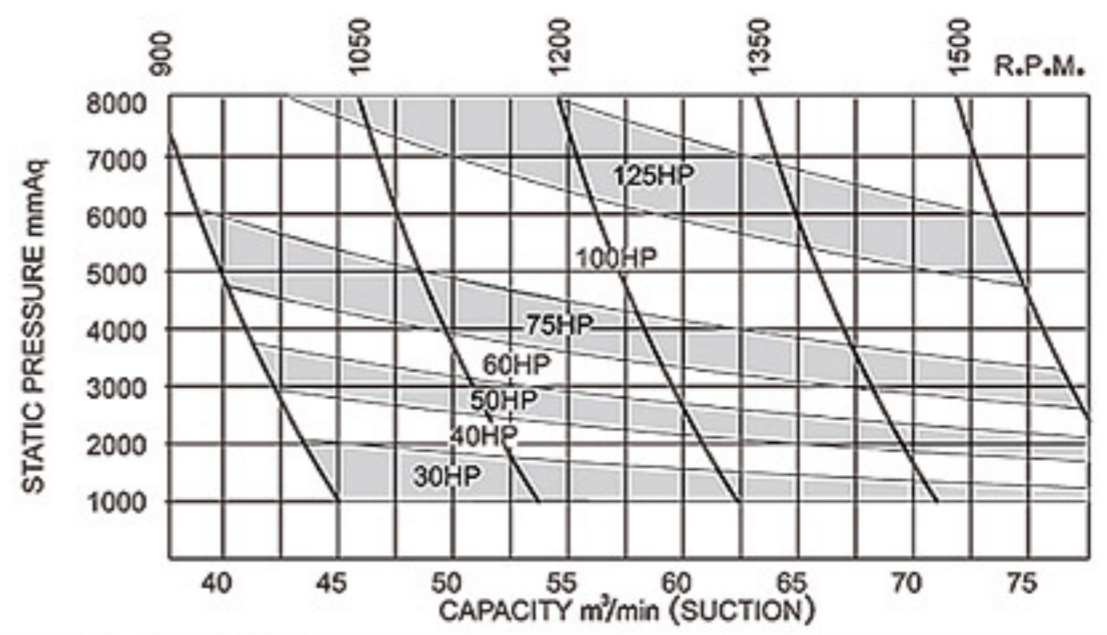

LT-250

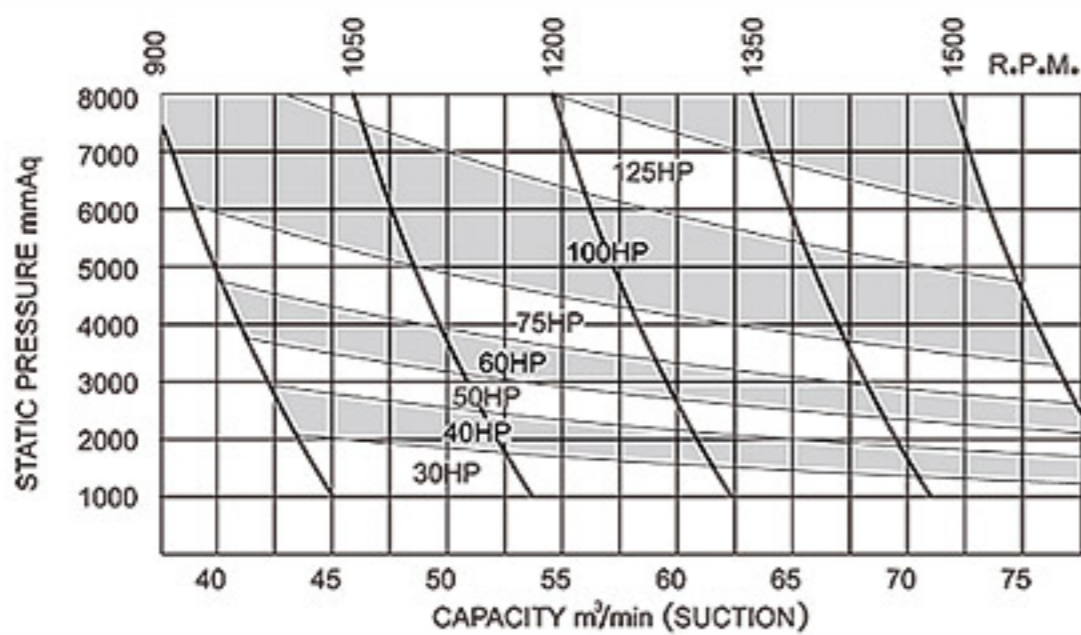

LT-300A

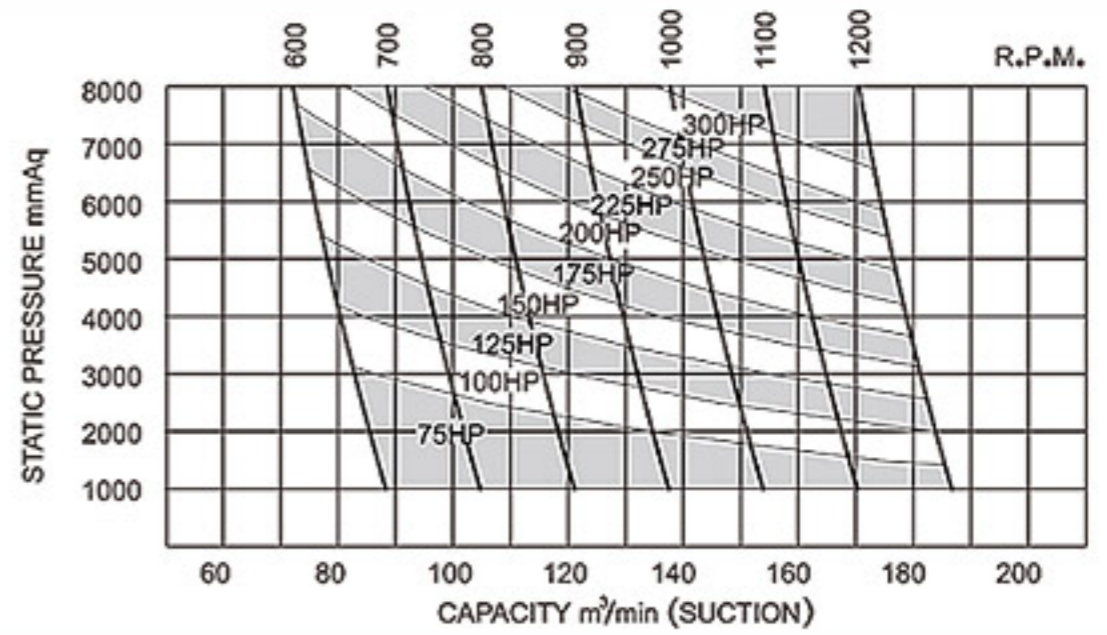

LT-250A

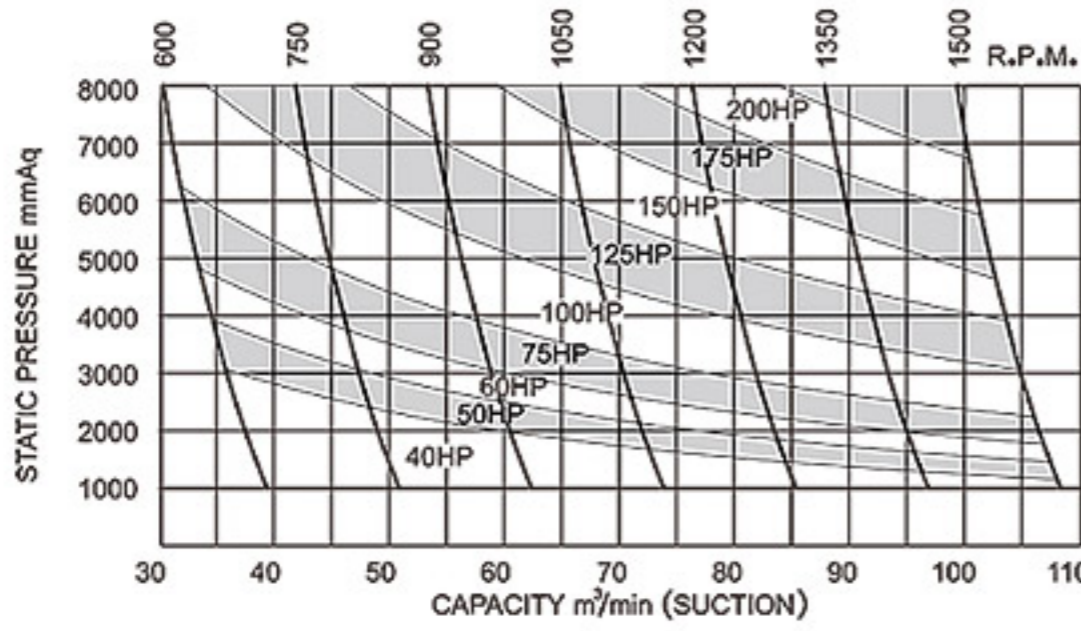

LT-350

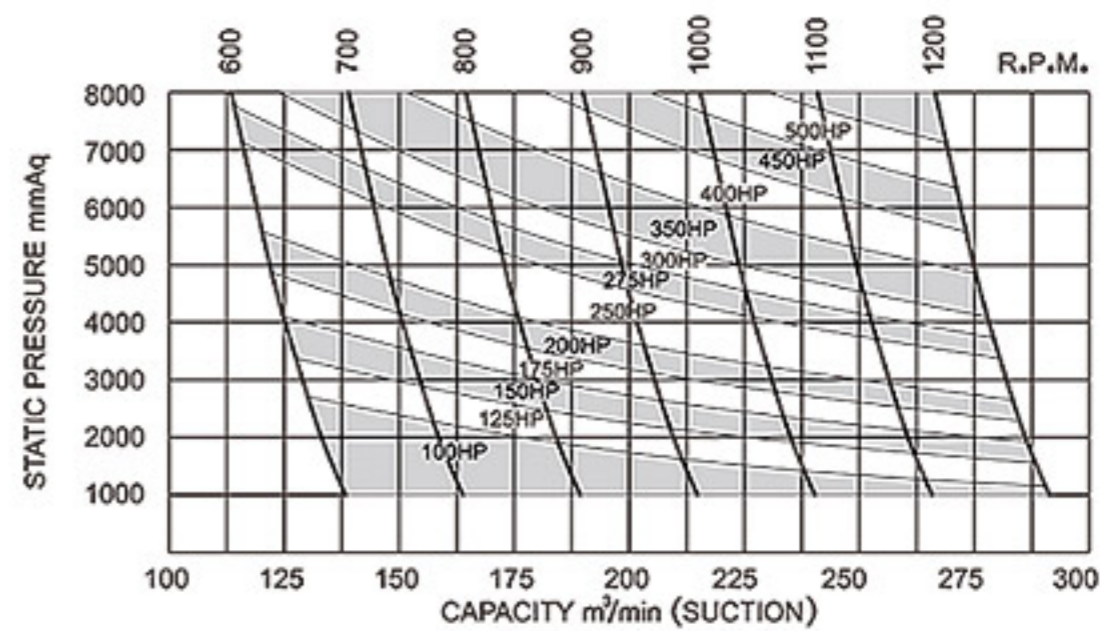

LT-300

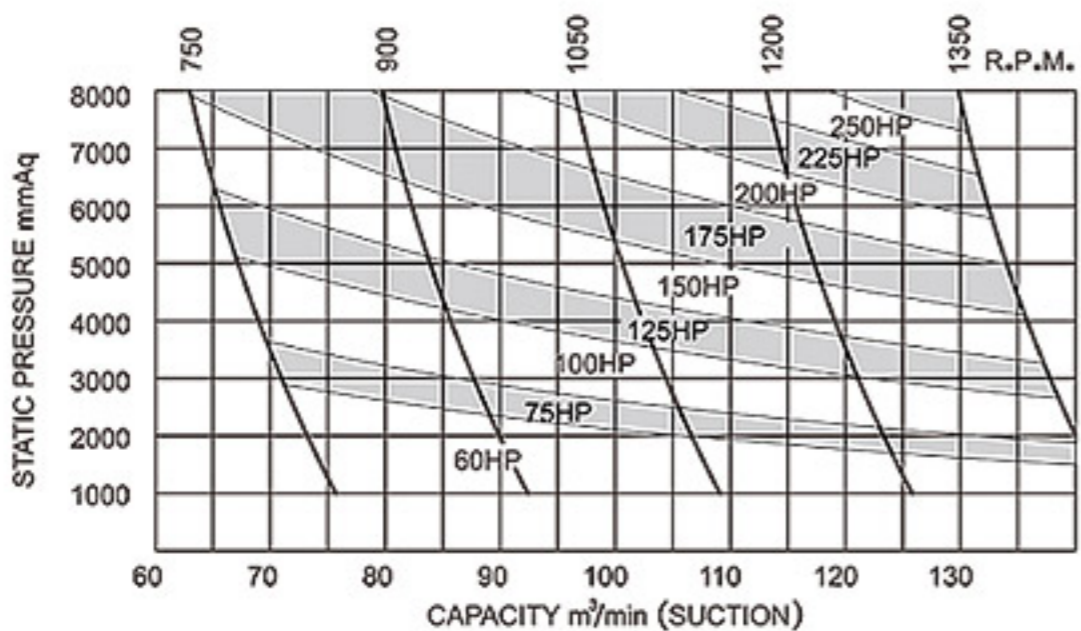

LT-400

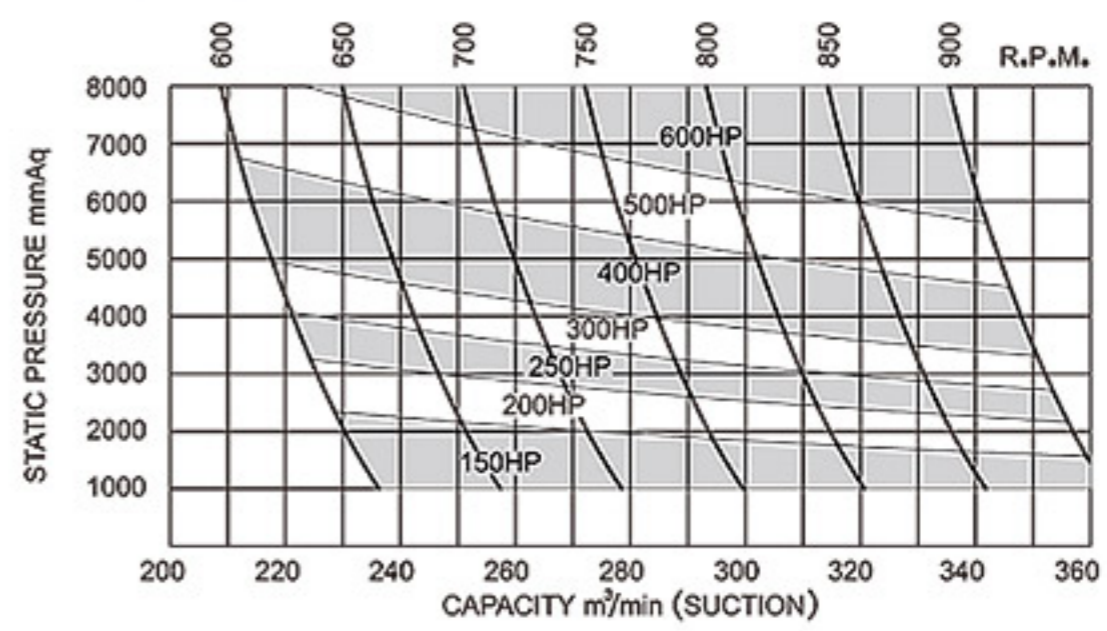

Vacuum Performance Table

TYPE	RPM	Qs(m ³ /min)				PRESSURE(mmAq)								La(Kw)			
		-1000mmAq		-2000mmAq		-2500mmAq		-3000mmAq		-3500mmAq		-4000mmAq		-5000mmAq		8000mmAq	
		Qs	La	Qs	La	Qs	La	Qs	La	Qs	La	Qs	La	Qs	La	Qs	La
LTV-040	1650	0.60	0.19	0.58	0.37	0.55	0.44	0.51	0.50	0.50	0.56	0.48	0.62				
	1800	0.68	0.21	0.65	0.40	0.62	0.48	0.59	0.55	0.58	0.61	0.55	0.67				
	1950	0.75	0.23	0.72	0.43	0.70	0.51	0.66	0.59	0.65	0.67	0.62	0.73				
	2100	0.83	0.24	0.80	0.47	0.77	0.55	0.74	0.64	0.72	0.72	0.70	0.79				
	2250	0.90	0.26	0.87	0.50	0.85	0.59	0.81	0.69	0.80	0.77	0.77	0.84				
	2400	0.97	0.28	0.95	0.53	0.92	0.63	0.88	0.73	0.87	0.82	0.85	0.90				
	2550	1.05	0.30	1.02	0.57	0.99	0.67	0.96	0.78	0.95	0.87	0.92	0.95				
LTV-050	850	0.99	0.41	0.82	0.80	0.72	0.98	0.61	1.16	0.51	1.34	0.36	1.51	0.27	1.67	0.14	1.84
	1000	1.31	0.48	1.14	0.94	1.04	1.16	0.93	1.37	0.83	1.57	0.69	1.77	0.59	1.97	0.46	2.16
	1150	1.63	0.56	1.47	1.08	1.36	1.33	1.25	1.57	1.15	1.81	1.01	2.04	0.91	2.27	0.79	2.49
	1300	1.95	0.63	1.79	1.22	1.69	1.50	1.58	1.78	1.48	2.05	1.33	2.31	1.24	2.56	1.11	2.81
	1450	2.27	0.70	2.11	1.36	2.01	1.68	1.90	1.98	1.80	2.28	1.65	2.57	1.56	2.86	1.43	3.13
	1600	2.60	0.77	2.43	1.50	2.33	1.85	2.22	2.19	2.12	2.52	1.97	2.84	1.88	3.15	1.75	3.46
	1750	2.92	0.85	2.75	1.64	2.65	2.02	2.54	2.39	2.44	2.75	2.29	3.11	2.20	3.45	2.07	3.78
LTV-065	850	2.09	0.66	1.91	1.28	1.80	1.58	1.68	1.87	1.55	2.15	1.41	2.42	1.26	2.69	1.09	2.95
	1000	2.60	0.78	2.43	1.51	2.32	1.86	2.19	2.20	2.07	2.53	1.92	2.85	1.77	3.16	1.60	3.47
	1150	3.12	0.89	2.95	1.73	2.84	2.14	2.71	2.53	2.58	2.91	2.44	3.28	2.29	3.64	2.12	3.99
	1300	3.64	1.01	3.46	1.96	3.35	2.41	3.23	2.86	3.10	3.29	2.96	3.71	2.81	4.11	2.64	4.51
	1450	4.15	1.13	3.98	2.19	3.87	2.69	3.74	3.19	3.62	3.67	3.47	4.13	3.32	4.59	3.15	5.03
	1600	4.67	1.24	4.50	2.41	4.39	2.97	4.26	3.52	4.13	4.05	3.99	4.56	3.84	5.06	3.67	5.55
	1750	5.19	1.36	5.01	2.64	4.90	3.25	4.78	3.85	4.65	4.42	4.51	4.99	4.36	5.54	4.19	6.08
LTV-080	850	3.24	1.12	2.83	2.14	2.60	2.62	2.36	3.08	2.10	3.52	1.83	3.94	1.54	4.34	1.23	4.73
	1000	4.14	1.32	3.73	2.52	3.50	3.08	3.26	3.62	3.00	4.14	2.73	4.63	2.44	5.11	2.13	5.57
	1150	5.04	1.51	4.63	2.90	4.40	3.54	4.16	4.16	3.90	4.76	3.63	5.33	3.34	5.88	3.03	6.40
	1300	5.94	1.71	5.53	3.27	5.30	4.01	5.06	4.71	4.80	5.38	4.53	6.02	4.24	6.64	3.93	7.24
	1450	6.84	1.91	6.43	3.65	6.20	4.47	5.96	5.25	5.70	6.00	5.43	6.72	5.14	7.41	4.83	8.08
	1600	7.74	2.11	7.33	4.03	7.10	4.93	6.86	5.79	6.60	6.62	6.33	7.41	6.04	8.18	5.73	8.91
	1750	8.64	2.30	8.23	4.41	8.00	5.39	7.76	6.33	7.50	7.24	7.23	8.11	6.94	8.94	6.63	9.75
LTV-100	850	5.79	1.57	5.19	3.00	4.85	3.67	4.48	4.31	4.09	4.92	3.67	5.51	3.22	6.08	2.74	6.63
	1000	7.05	1.84	6.45	3.53	6.11	4.31	5.74	5.07	5.35	5.79	4.93	6.49	4.48	7.15	4.00	7.80
	1150	8.31	2.12	7.71	4.05	7.37	4.96	7.00	5.83	6.61	6.66	6.19	7.46	5.74	8.23	5.26	8.97
	1300	9.57	2.40	8.97	4.58	8.63	5.61	8.26	6.59	7.87	7.53	7.45	8.43	7.00	9.30	6.52	10.14
	1450	10.83	2.67	10.23	5.11	9.89	6.25	9.52	7.35	9.13	8.40	8.71	9.41	8.26	10.37	7.78	11.31
	1600	12.09	2.95	11.49	5.64	11.15	6.90	10.78	8.11	10.39	9.27	9.97	10.38	9.52	11.45	9.04	12.47
	1750	13.35	3.23	12.75	6.17	12.41	7.55	12.04	8.87	11.65	10.14	11.23	11.35	10.78	12.52	10.30	13.64

Vacuum Performance Table

TYPE	RPM	Qs(m ³ /min)				PRESSURE(mmAq)								La(Kw)			
		-1000mmAq		-2000mmAq		-2500mmAq		-3000mmAq		-3500mmAq		-4000mmAq		-4500mmAq		-5000mmAq	
		Qs	La	Qs	La	Qs	La	Qs	La	Qs	La	Qs	La	Qs	La	Qs	La
LTV-125 S	750	8.13	2.05	7.35	3.91	6.93	4.79	6.48	5.63	6.01	6.43	5.53	7.20	5.00	7.94	4.46	8.66
	900	10.02	2.46	9.24	4.70	8.82	5.75	8.37	6.75	7.90	7.72	7.42	8.64	6.89	9.53	6.35	10.39
	1050	11.91	2.86	11.13	5.48	10.71	6.70	10.26	7.88	9.79	9.00	9.31	10.08	8.78	11.12	8.24	12.12
	1200	13.80	3.27	13.02	6.26	12.60	7.66	12.15	9.00	11.68	10.29	11.20	11.52	10.67	12.71	10.13	13.85
	1350	15.69	3.68	14.91	7.04	14.49	8.62	14.04	10.13	13.57	11.57	13.09	12.96	12.56	14.30	12.02	15.59
	1500	17.58	4.09	16.80	7.83	16.38	9.58	15.93	11.25	15.46	12.86	14.98	14.40	14.45	15.89	13.91	17.32
	1650	19.47	4.50	18.69	8.61	18.27	10.53	17.82	12.38	17.35	14.14	16.87	15.84	16.34	17.48	15.80	19.05
LTV-125	750	10.29	2.59	9.30	4.96	8.78	6.06	8.20	7.13	7.61	8.14	7.01	9.12	6.34	10.06	5.65	10.97
	900	12.69	3.11	11.70	5.95	11.17	7.28	10.60	8.55	10.01	9.77	9.40	10.95	8.73	12.07	8.04	13.16
	1050	15.08	3.63	14.09	6.94	13.57	8.49	12.99	9.98	12.40	11.40	11.79	12.77	11.12	14.09	10.44	15.35
	1200	17.48	4.15	16.49	7.93	15.96	9.70	15.39	11.40	14.79	13.03	14.19	14.59	13.52	16.10	12.83	17.55
	1350	19.87	4.66	18.88	8.92	18.35	10.92	17.78	12.83	17.19	14.66	16.58	16.42	15.91	18.11	15.23	19.74
	1500	22.26	5.18	21.27	9.91	20.75	12.13	20.17	14.25	19.58	16.29	18.98	18.24	18.31	20.12	17.62	21.93
	1650	24.66	5.70	23.67	10.90	23.14	13.34	22.57	15.68	21.98	17.92	21.37	20.07	20.70	22.14	20.01	24.13
LTV-150	750	13.32	3.34	12.55	6.39	12.14	7.82	11.69	9.19	11.20	10.50	10.68	11.76	10.13	12.97	9.55	14.14
	900	16.40	4.01	15.64	7.67	15.23	9.38	14.78	11.03	14.28	12.60	13.77	14.11	13.21	15.57	12.64	16.97
	1050	19.49	4.68	18.73	8.95	18.32	10.95	17.86	12.86	17.37	14.70	16.86	16.47	16.30	18.16	15.72	19.80
	1200	22.58	5.35	21.81	10.23	21.40	12.51	20.95	14.70	20.46	16.80	19.94	18.82	19.39	20.76	18.81	22.62
	1350	25.66	6.02	24.90	11.50	24.49	14.07	24.04	16.54	23.54	18.90	23.03	21.17	22.47	23.35	21.90	25.45
	1500	28.75	6.68	27.99	12.78	27.58	15.64	27.12	18.38	26.63	21.00	26.12	23.52	25.56	25.95	24.98	28.28
	1650	31.84	7.35	31.08	14.06	30.66	17.20	30.21	20.21	29.72	23.10	29.20	25.88	28.65	28.54	28.07	31.11
LTV-200	600	17.01	4.84	15.99	9.27	15.42	11.34	14.86	13.32	14.21	15.23	13.49	17.06	12.78	18.82	11.98	20.51
	750	22.68	6.05	21.66	11.58	21.09	14.17	20.53	16.65	19.88	19.04	19.16	21.32	18.45	23.52	17.65	25.64
	900	28.35	7.27	27.33	13.90	26.76	17.01	26.20	19.98	25.55	22.84	24.83	25.59	24.12	28.23	23.32	30.77
	1050	34.02	8.48	33.00	16.22	32.43	19.84	31.87	23.32	31.22	26.65	30.50	29.85	29.79	32.93	28.99	35.89
	1200	39.69	9.69	38.67	18.53	38.10	22.67	37.54	26.65	36.89	30.46	36.17	34.12	35.46	37.64	34.66	41.02
	1350	45.36	10.90	44.34	20.85	43.77	25.51	43.21	29.98	42.56	34.26	41.84	38.38	41.13	42.34	40.33	46.15
	1500	51.03	12.11	50.01	23.17	49.44	28.34	48.88	33.31	48.23	38.07	47.51	42.65	46.80	47.05	46.00	51.28
LTV-200A	600	27.72	7.40	26.22	14.16	25.35	17.32	24.43	20.35	23.45	23.27	22.35	26.06	21.19	28.75	19.98	31.34
	750	36.38	9.25	34.88	17.70	34.01	21.65	33.09	25.44	32.11	29.08	31.01	32.58	29.86	35.94	28.64	39.17
	900	45.05	11.10	43.54	21.24	42.68	25.98	41.75	30.53	40.77	34.90	39.67	39.09	38.52	43.13	37.31	47.01
	1050	53.71	12.95	52.21	24.77	51.34	30.31	50.42	35.62	49.43	40.72	48.34	45.61	47.18	50.31	45.97	54.84
	1200	62.37	14.80	60.87	28.31	60.00	34.64	59.08	40.71	58.10	46.53	57.00	52.12	55.84	57.50	54.63	62.67
	1350	71.03	16.65	69.53	31.85	68.66	38.97	67.74	45.80	66.76	52.35	65.66	58.64	64.51	64.69	63.29	70.51
	1500	79.70	18.50	78.19	35.39	77.33	43.30	76.40	50.89	75.42	58.16	74.32	65.16	73.17	71.88	71.96	78.34

Vacuum Performance Table

TYPE	RPM	Qs(m ³ /min)				PRESSURE(mmAq)								La(Kw)			
		-1000mmAq		-2000mmAq		-2500mmAq		-3000mmAq		-3500mmAq		-4000mmAq		-4500mmAq		-5000mmAq	
		Qs	La	Qs	La	Qs	La	Qs	La	Qs	La	Qs	La	Qs	La	Qs	La
LTV-250	600	27.72	7.40	26.22	14.16	25.35	17.32	24.43	20.35	23.45	23.27	22.35	26.06	21.19	28.75	19.98	31.34
	750	36.38	9.25	34.88	17.70	34.01	21.65	33.09	25.44	32.11	29.08	31.01	32.58	29.86	35.94	28.64	39.17
	900	45.05	11.10	43.54	21.24	42.68	25.98	41.75	30.53	40.77	34.90	39.67	39.09	38.52	43.13	37.31	47.01
	1050	53.71	12.95	52.21	24.77	51.34	30.31	50.42	35.62	49.43	40.72	48.34	45.61	47.18	50.31	45.97	54.84
	1200	62.37	14.80	60.87	28.31	60.00	34.64	59.08	40.71	58.10	46.53	57.00	52.12	55.84	57.50	54.63	62.67
	1350	71.03	16.65	69.53	31.85	68.66	38.97	67.74	45.80	66.76	52.35	65.66	58.64	64.51	64.69	63.29	70.51
	1500	79.70	18.50	78.19	35.39	77.33	43.30	76.40	50.89	75.42	58.16	74.32	65.16	73.17	71.88	71.96	78.34
LTV-250A	600	39.31	10.34	37.13	17.81	35.63	21.47	34.37	25.13	33.01	28.89	31.74	32.48	30.37	35.83	28.82	39.97
	750	50.78	12.92	48.60	22.26	47.09	26.84	45.84	31.41	44.48	36.12	43.21	40.59	41.83	44.78	40.29	49.97
	900	62.25	15.50	60.07	26.72	58.56	32.21	57.31	37.70	55.95	43.34	54.68	48.71	53.30	53.74	51.76	59.96
	1050	73.71	18.09	71.53	31.17	70.03	37.57	68.77	43.98	67.41	50.57	66.14	56.83	64.77	62.70	63.22	69.95
	1200	85.18	20.67	83.00	35.62	81.50	42.94	80.24	50.26	78.88	57.79	77.61	64.95	76.24	71.65	74.69	79.95
	1350	96.65	23.26	94.47	40.07	92.96	48.31	91.71	56.55	90.35	65.01	89.08	73.07	87.70	80.61	86.16	89.94
	1500	108.10	25.84	105.9	44.53	104.4	53.68	103.2	62.83	101.8	72.24	100.5	81.19	99.17	89.57	97.63	99.93
LTV-300	600	58.94	14.25	56.27	27.26	54.82	33.35	53.15	39.19	51.49	44.80	49.71	50.18	47.70	55.36	45.70	60.34
	750	75.62	17.81	72.95	34.07	71.50	41.69	69.83	48.99	68.17	56.00	66.39	62.72	64.38	69.20	63.38	75.42
	900	92.30	21.38	89.63	40.89	88.18	50.02	86.51	58.79	84.85	67.20	83.07	75.27	81.06	83.04	79.06	90.51
	1050	109.0	24.94	106.3	47.70	104.9	58.36	103.2	68.58	101.5	78.40	99.75	87.81	97.74	96.88	95.74	105.6
	1200	125.7	28.50	123.0	54.52	121.5	66.70	119.9	78.38	118.2	89.60	116.4	100.4	114.4	110.7	112.4	120.7
	1350	142.3	32.06	139.7	61.33	138.2	75.04	136.6	88.18	134.9	100.8	133.1	112.9	131.1	124.6	129.1	135.8
	1500	159.0	35.63	156.3	68.15	154.9	83.37	153.2	97.98	151.6	112.0	149.8	125.4	147.8	138.4	145.8	150.8
LTV-300A	600	88.2	21.04	84.4	36.86	82.0	44.47	79.7	53.34	77.7	60.6	75.3	68.0	72.5	77.0	69.0	84.7
	700	104.6	24.54	100.9	43.01	98.4	51.88	96.2	62.23	94.1	70.6	91.8	79.4	89.0	89.8	85.5	98.9
	800	121.0	28.05	117.3	49.15	114.8	59.29	112.6	71.12	110.5	80.7	108.2	90.7	105.4	102.7	101.9	113.0
	900	137.5	31.56	133.7	55.29	131.3	66.70	129.1	80.00	127.0	90.8	124.7	102.0	121.8	115.5	118.4	127.1
	1000	153.9	35.06	150.2	61.44	147.7	74.11	145.5	88.89	143.4	100.9	141.1	113.4	138.3	128.3	134.8	141.2
	1100	170.3	38.57	166.6	67.58	164.1	81.52	161.9	97.78	159.9	111.0	157.5	124.7	154.7	141.2	151.2	155.3
	1200	186.8	42.07	183.0	73.72	180.6	88.93	178.4	106.7	176.3	121.1	174.0	136.1	171.1	154.0	167.7	169.5
LTV-350	600	138.1	32.72	132.3	57.32	128.5	69.15	124.7	82.94	121.4	94.16	117.9	105.8	113.5	119.8	107.9	131.7
	700	163.6	38.17	157.8	66.87	154.0	80.67	150.2	96.77	146.9	109.9	143.4	123.4	139.0	139.7	133.4	153.7
	800	189.1	43.63	183.3	76.42	179.5	92.20	175.7	110.6	172.4	125.6	168.9	141.1	164.5	159.7	158.9	175.7
	900	214.6	49.08	208.8	85.97	205.0	103.7	201.2	124.4	197.9	141.2	194.4	158.7	190.0	179.6	184.4	197.6
	1000	240.1	54.53	234.3	95.53	230.5	115.2	226.7	138.2	223.4	156.9	219.9	176.3	215.5	199.6	209.9	219.6
	1100	265.6	59.99	259.8	105.1	256.0	126.8	252.2	152.1	248.9	172.6	245.4	193.9	241.0	219.6	235.4	241.5
	1200	291.1	65.44	285.3	114.6	281.5	138.3	277.7	165.9	274.4	188.3	270.9	211.6	266.5	239.5	260.9	263.5
LTV-400	600	236.3	52.99	228.3	95.77	224.6	117.3	219.5	137.9	216.6	159.0	212.4	180.5	209.4	212.8	203.5	223.0
	650	257.4	57.40	249.4	103.8	245.6	127.1	240.5	149.4	237.6	172.3	233.4	195.5	230.5	230.5	224.6	241.6
	700	278.4	61.82	270.4	111.7	266.6	136.8	261.6	160.9	258.6	185.5	254.4	210.6	251.5	248.3	245.6	260.2
	750	299.4	66.23	291.4	119.7	287.6	146.6	282.6	172.4	279.7	198.8	275.4	225.6	272.5	266.0	266.6	278.8
	800	320.4	70.65	312.5	127.7	308.7	156.4	303.6	183.9	300.7	212.0	296.5	240.7	293.5	283.7	287.6	297.3
	850	341.5	75.07	333.5	135.7	329.7	166.2	324.6	195.4	321.7	225.3	317.5	255.7	314.6	301.5	308.7	315.9
	900	362.5	79.48	354.5	143.7	350.7	175.9	345.7	206.9	342.7	238.5	338.5	270.7	335.6	319.2	329.7	334.5

Vacuum Performance Curve

LTV-040

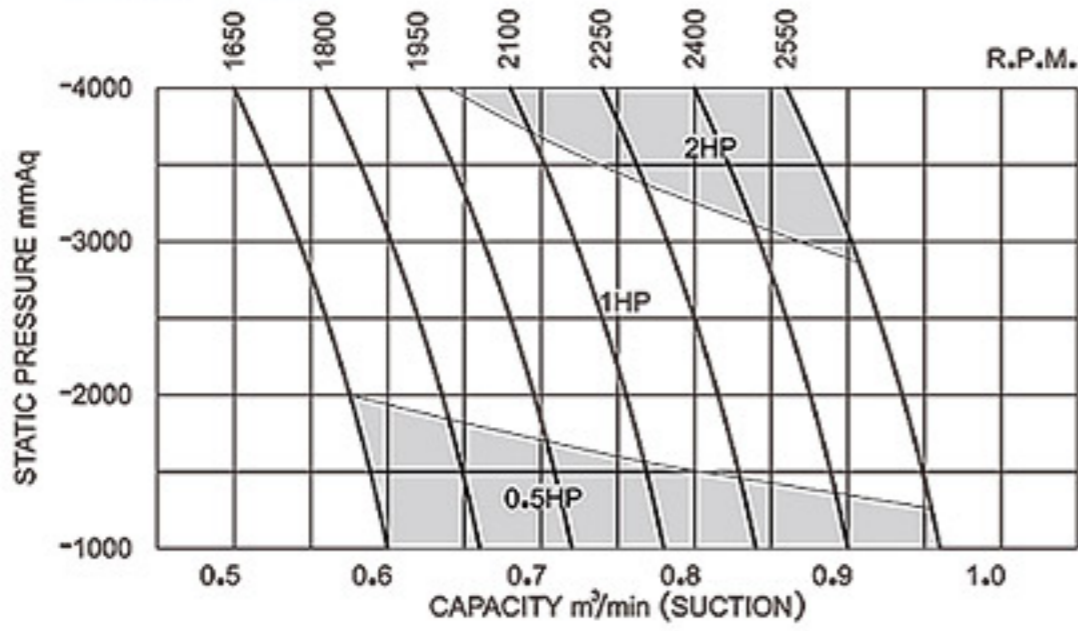

LTV-100

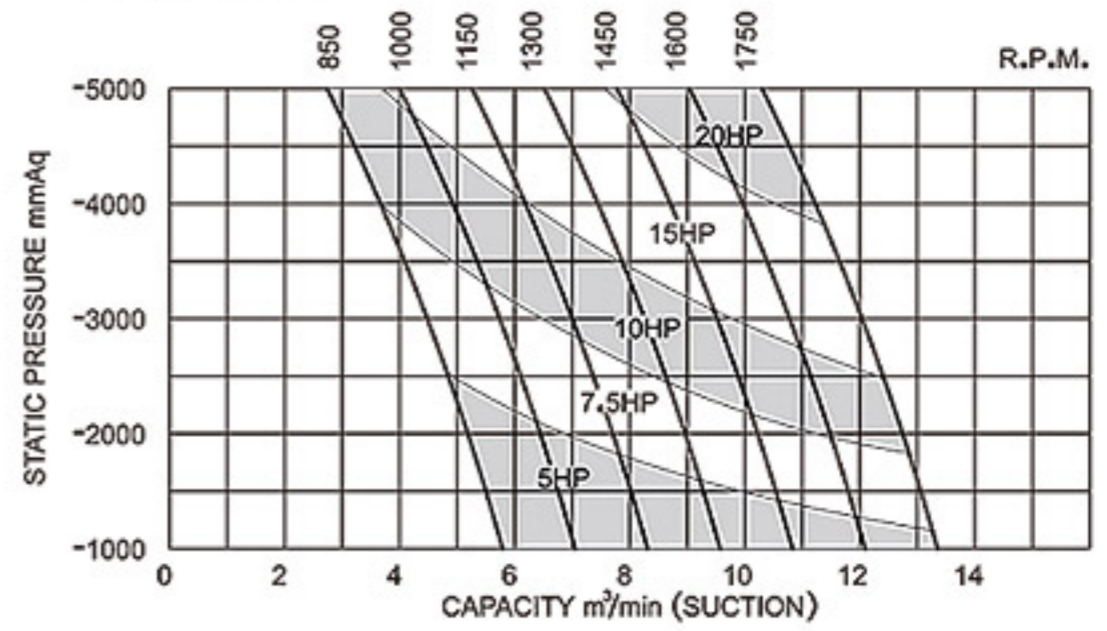

LTV-050

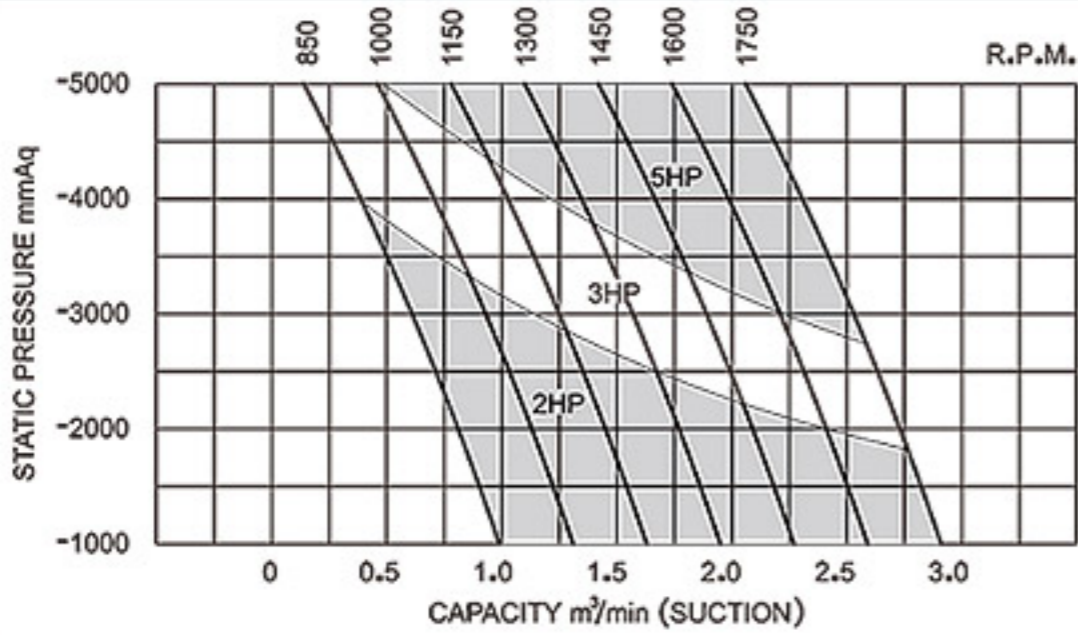

LTV-125S

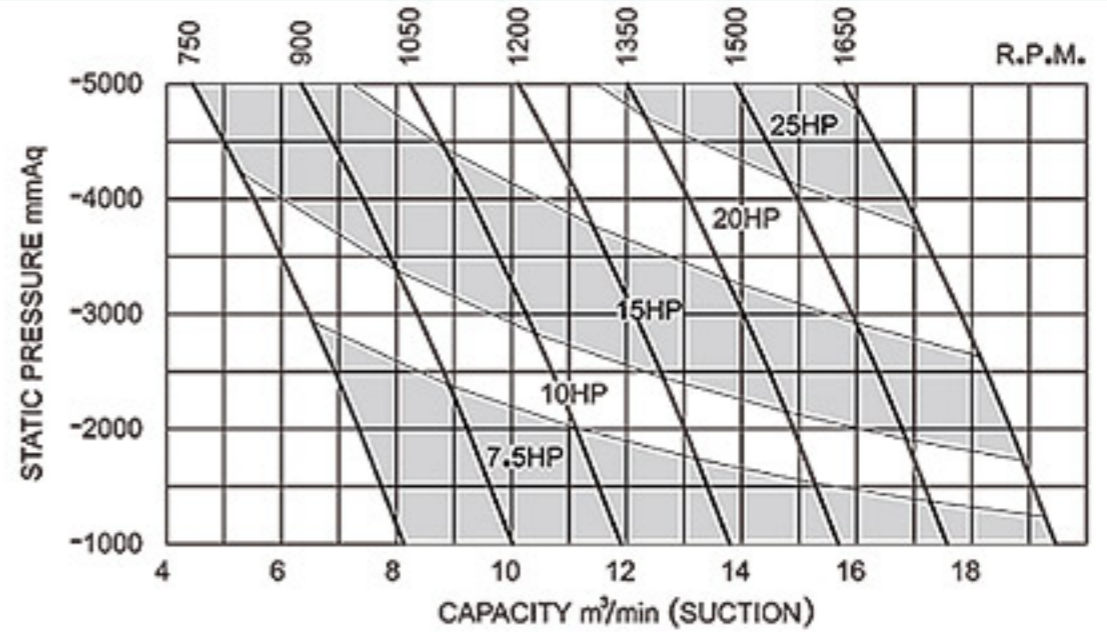

LTV-065

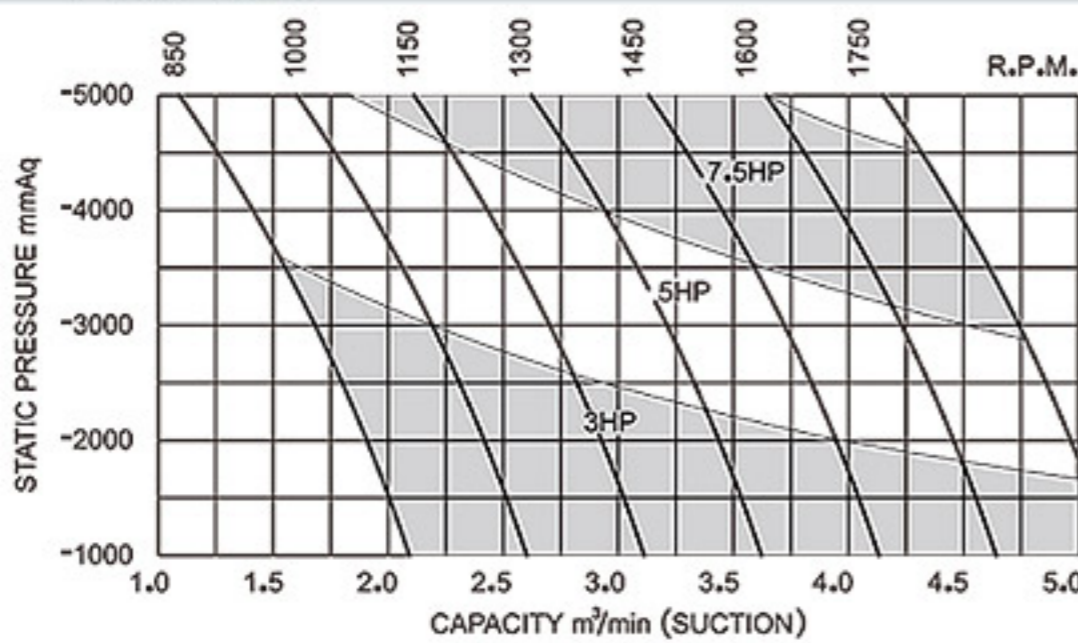

LTV-125

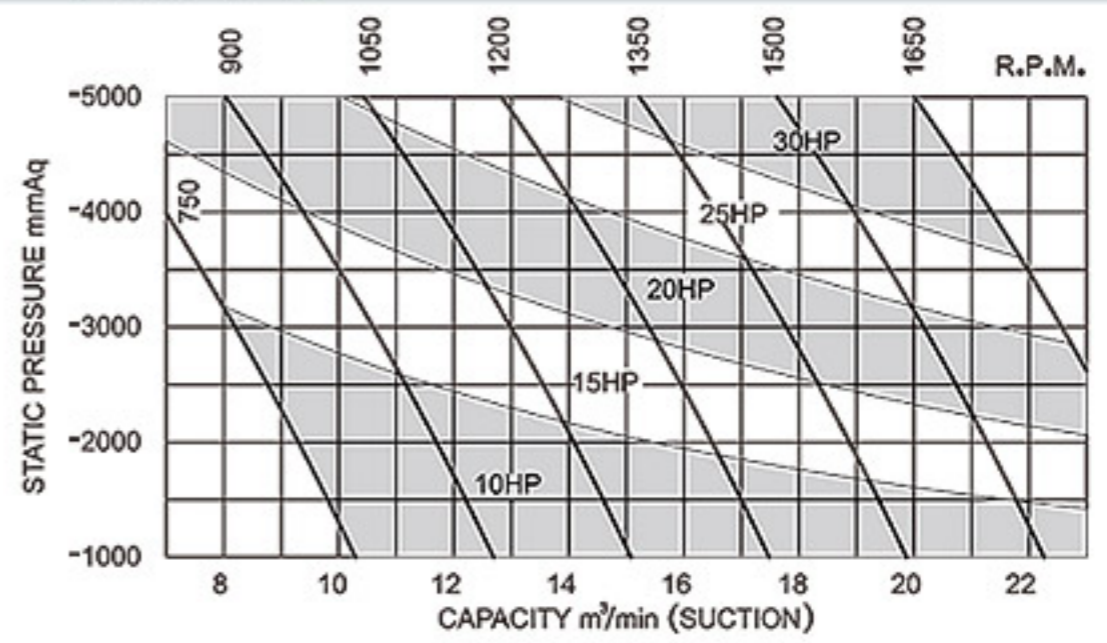

LTV-080

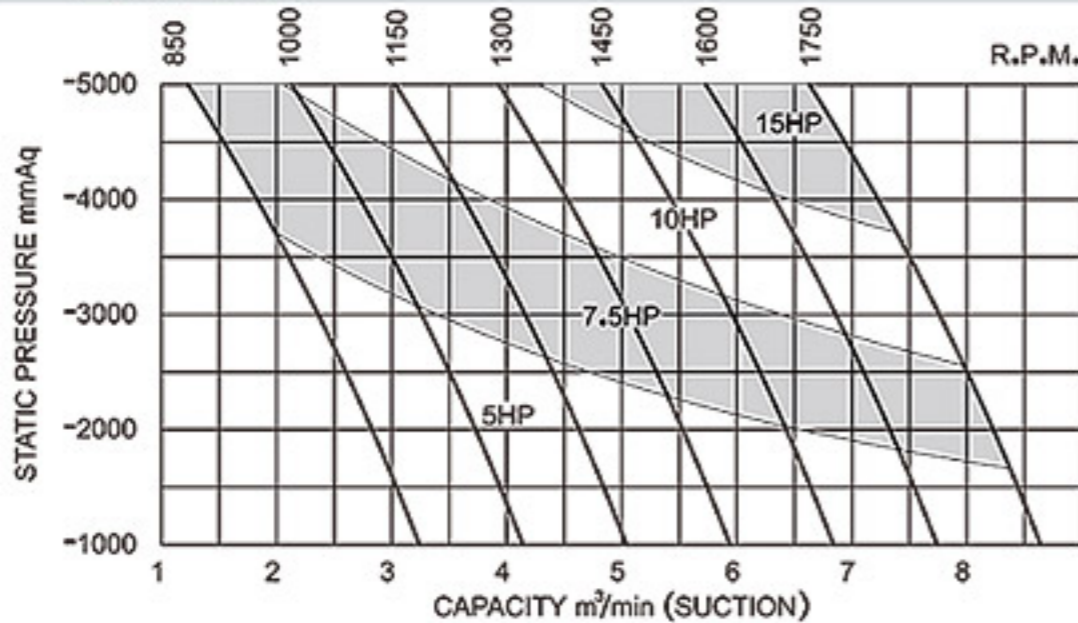

LTV-150

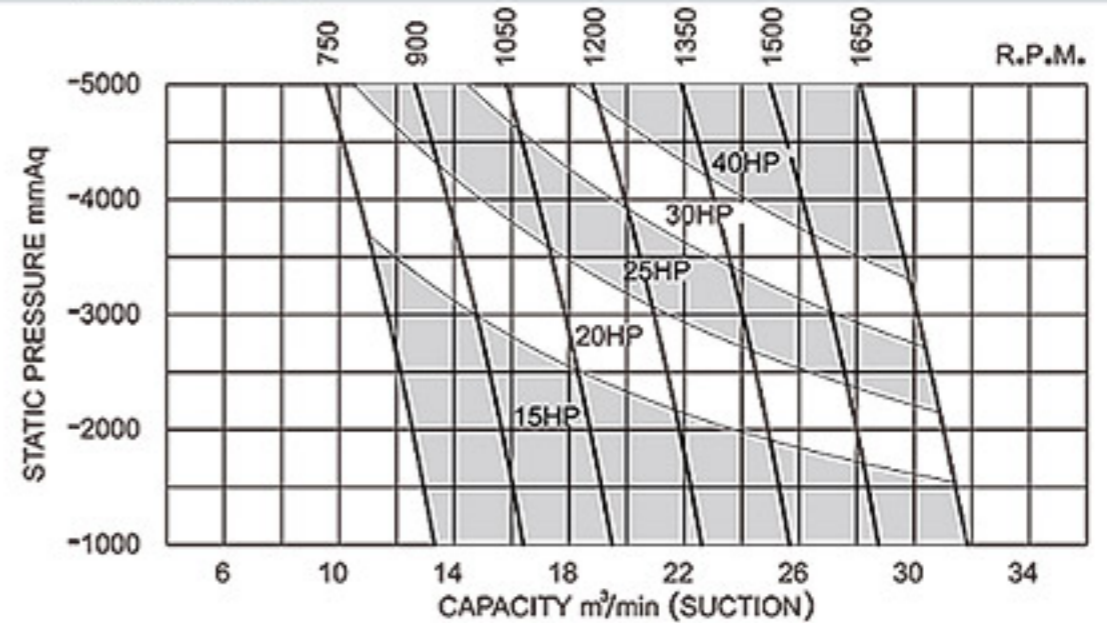

Vacuum Performance Curve

LTV-200

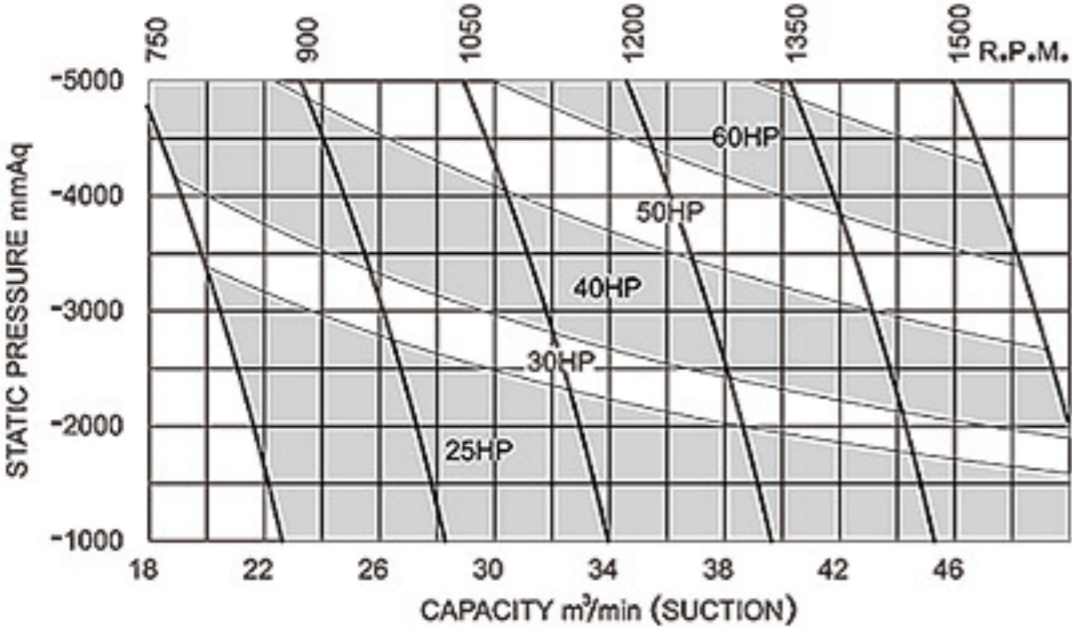

LTV-200A

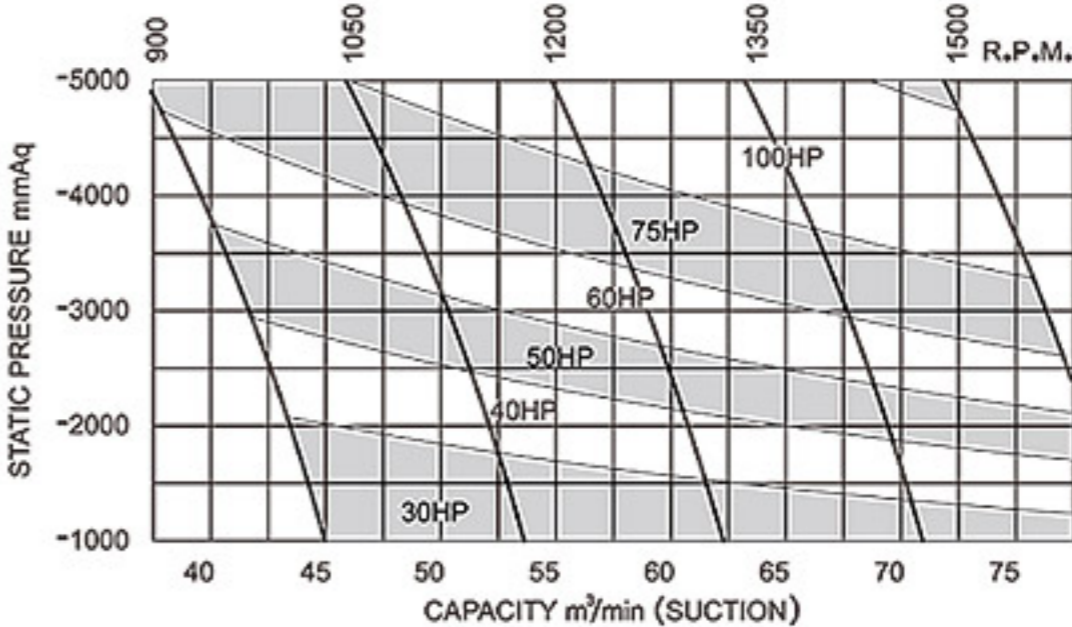

LTV-250

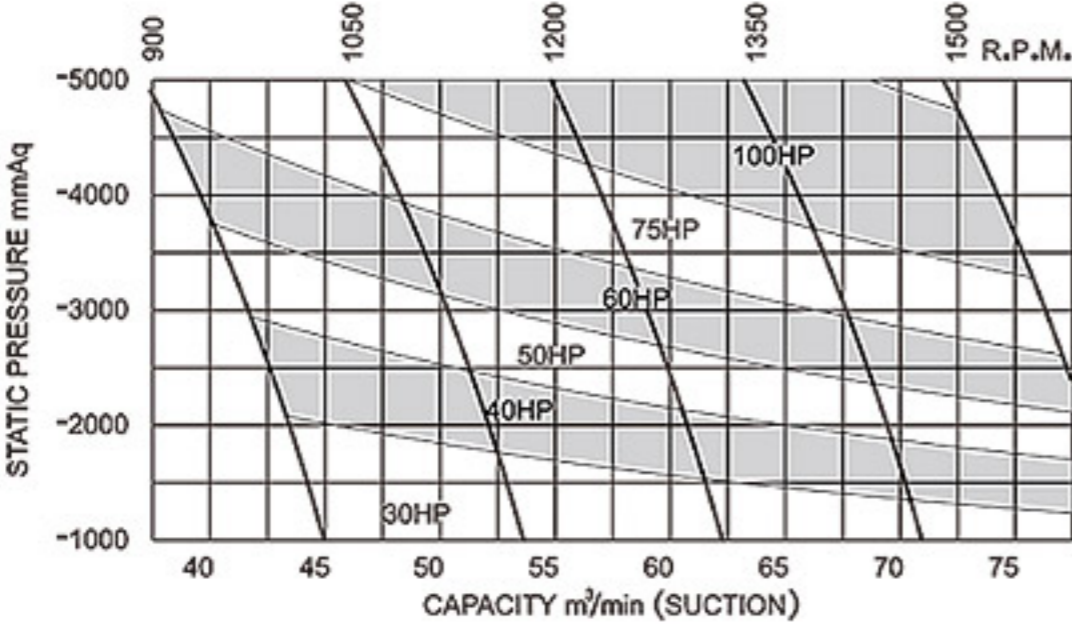

LTV-300A

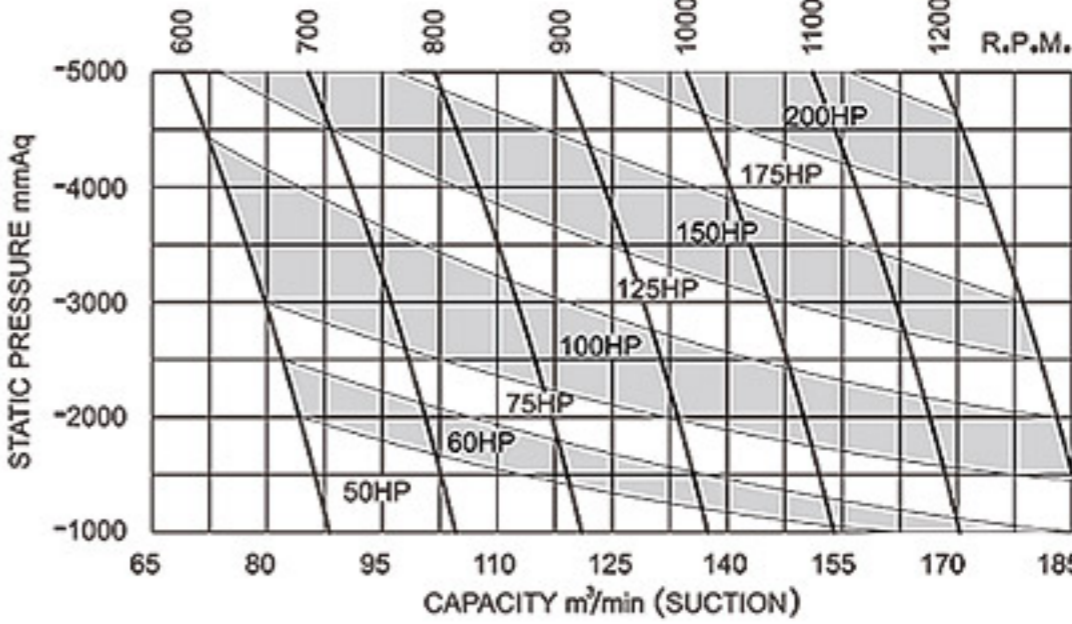

LTV-250A

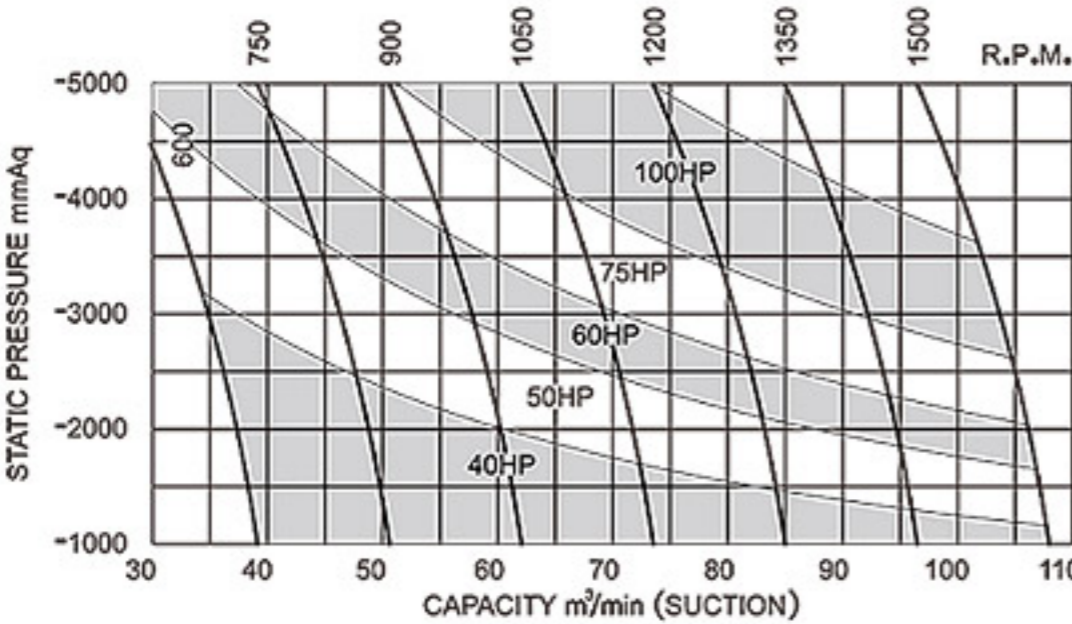

LTV-350

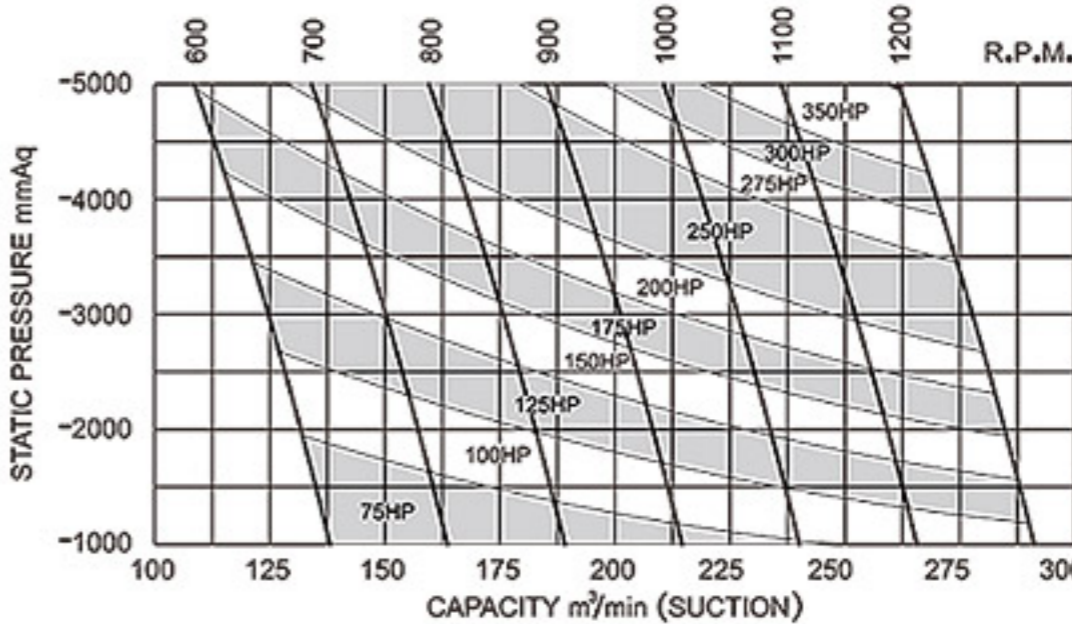

LTV-300

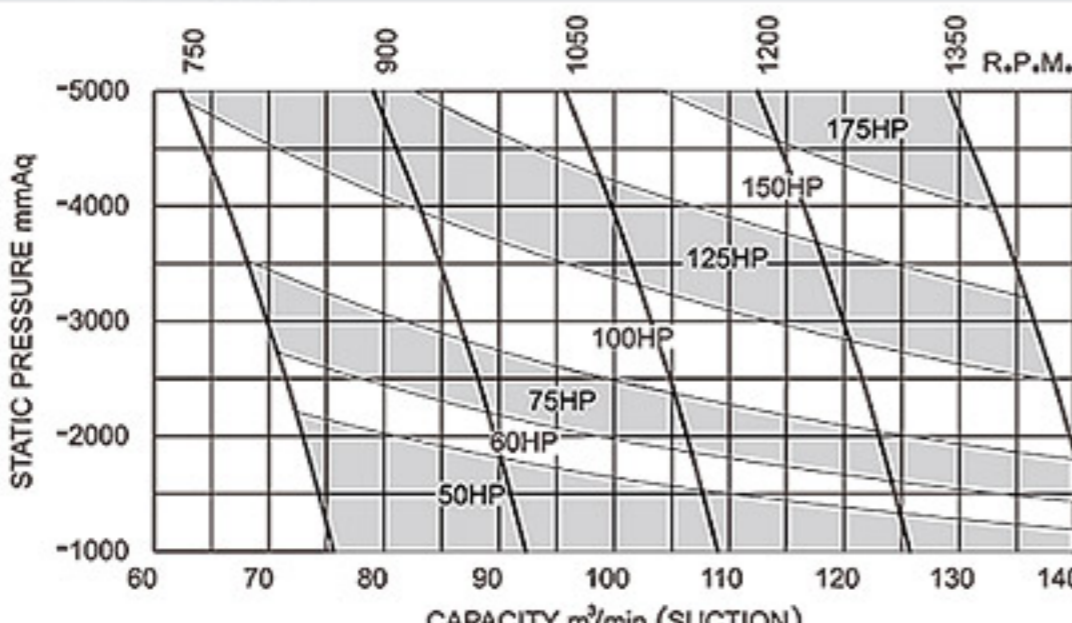

LTV-400

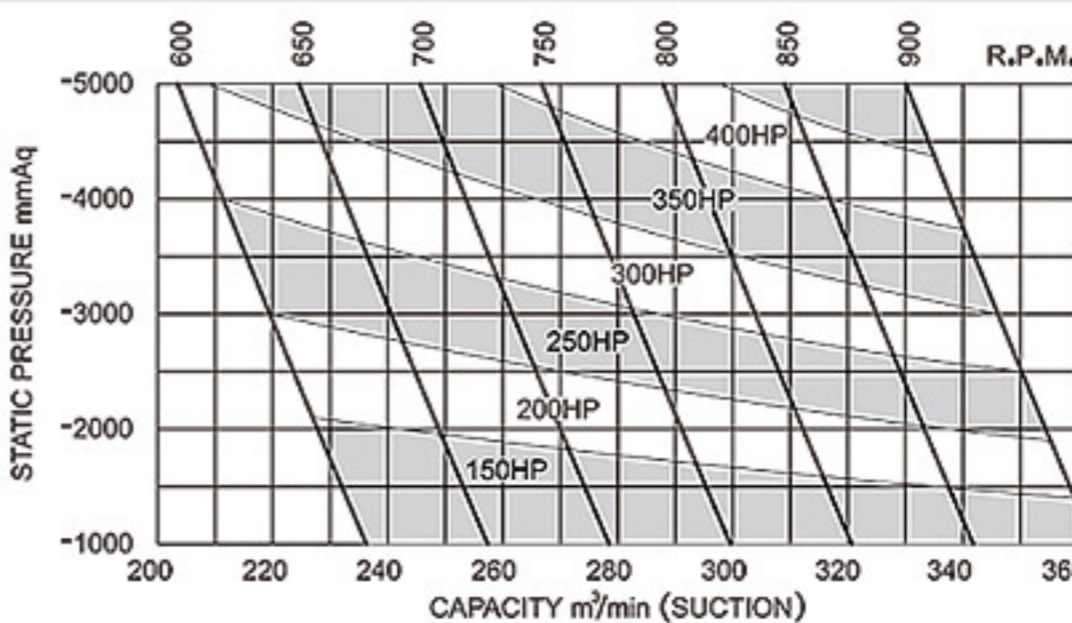

Noise Performance Specifications

LT / LTV-040

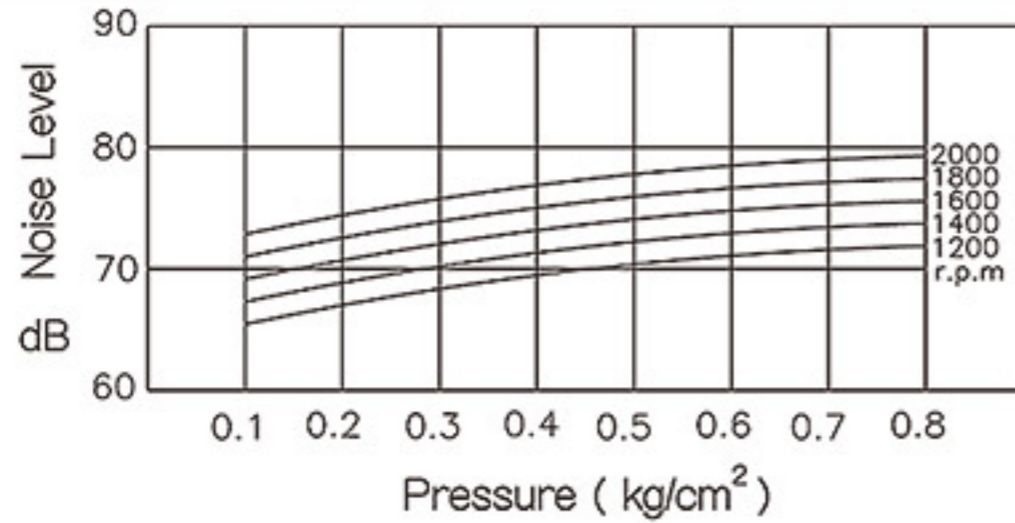

LT / LTV-100

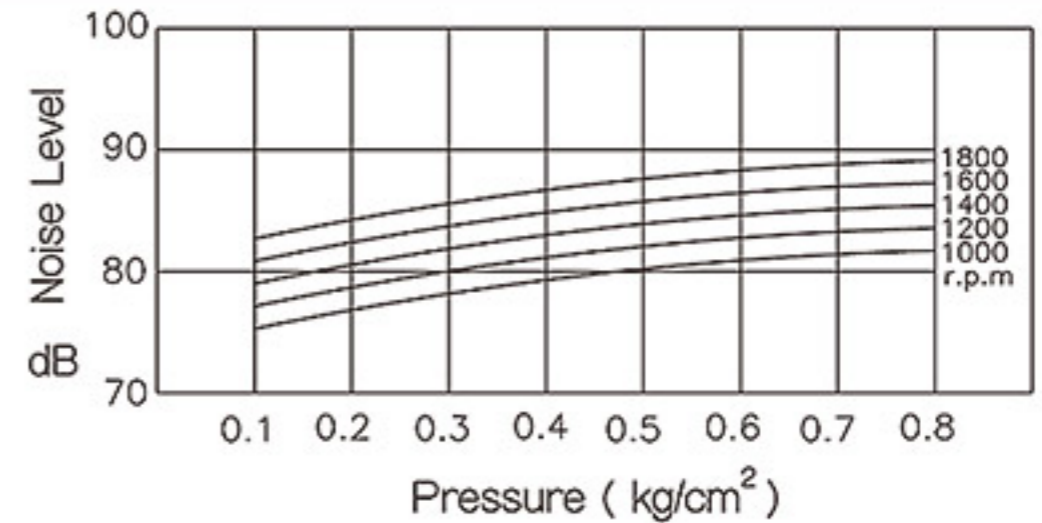

LT / LTV-050

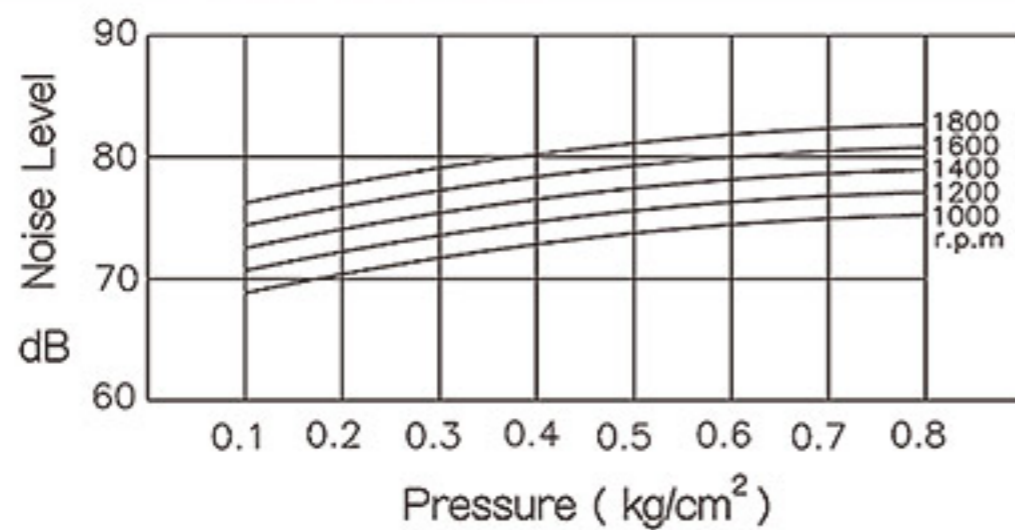

LT / LTV-125S

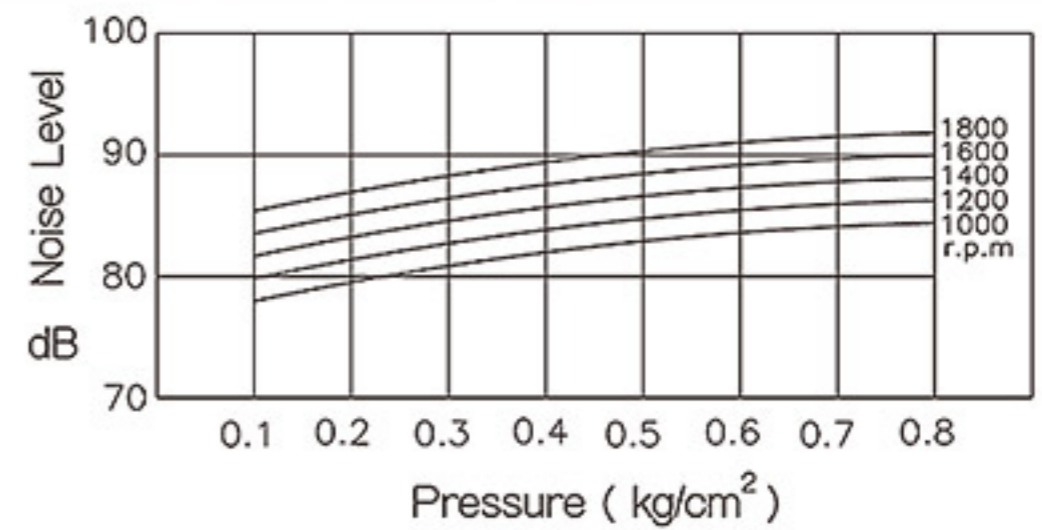

LT / LTV-065

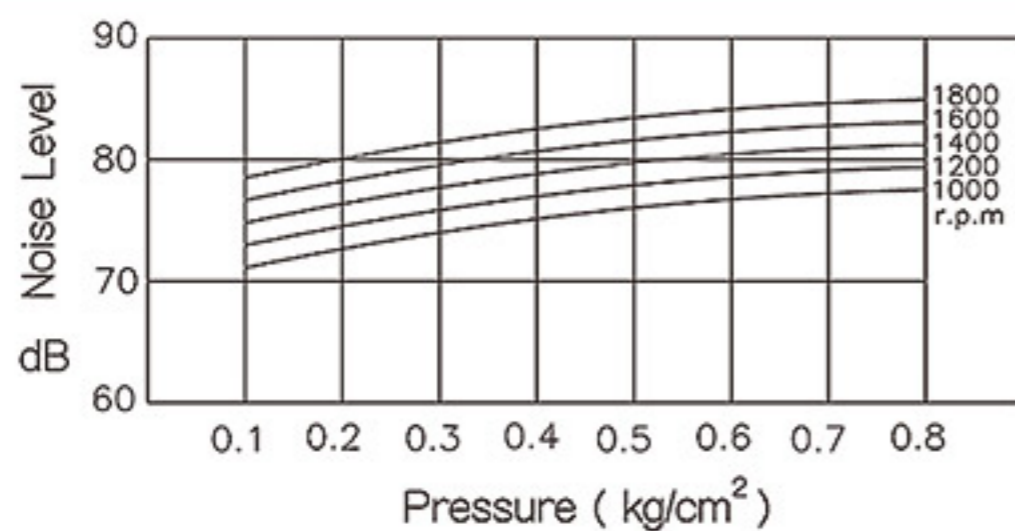

LT / LTV-125

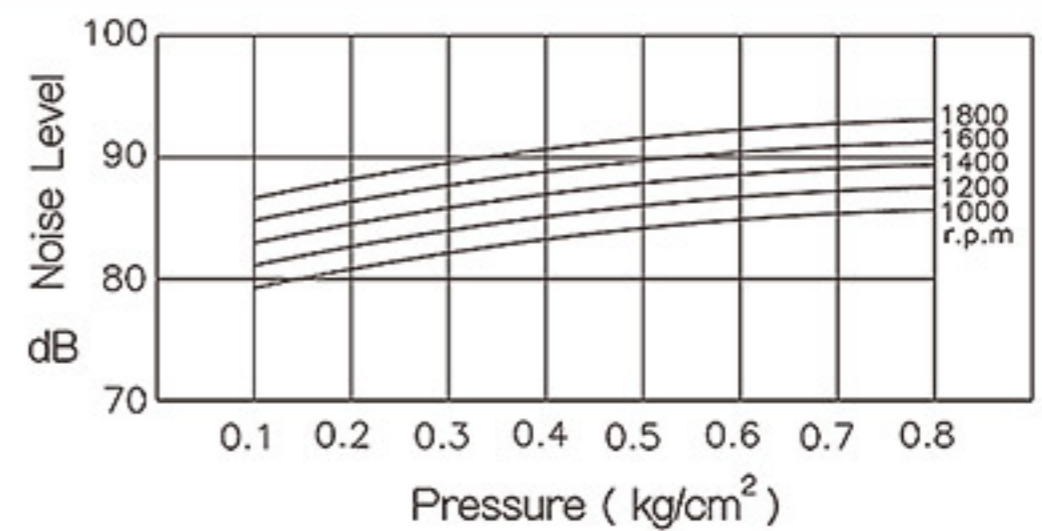

LT / LTV-080

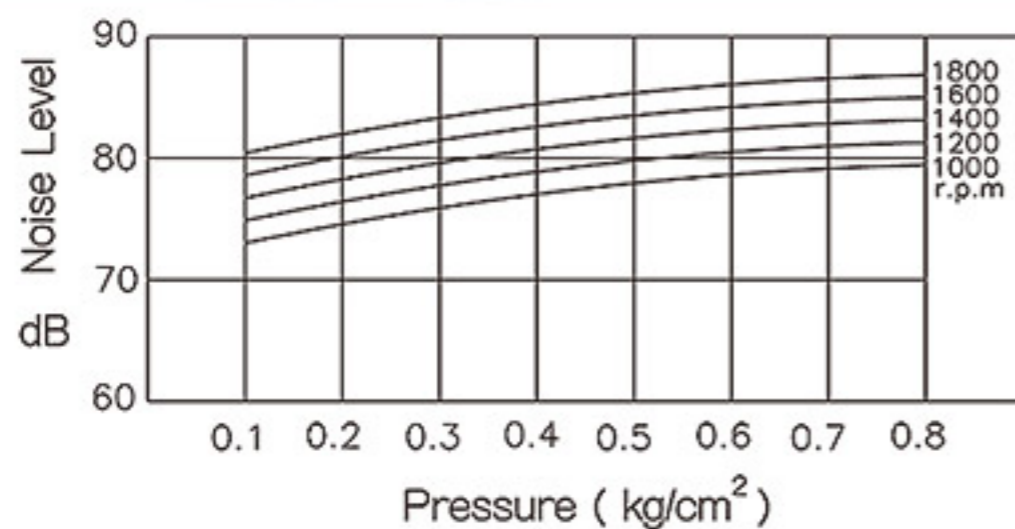

LT / LTV-150

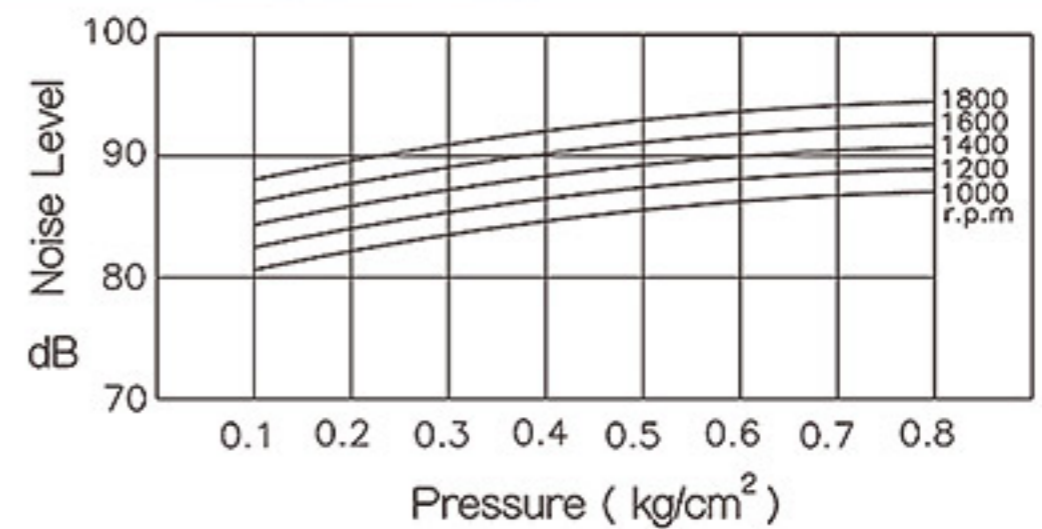

◆ | Noise level measured at distance 1 meter for the blower fitted with standard silenced

◆ | Noise level maybe different according to the extend pipe length and ambient condition

Noise Performance Specifications

LT / LTV-200

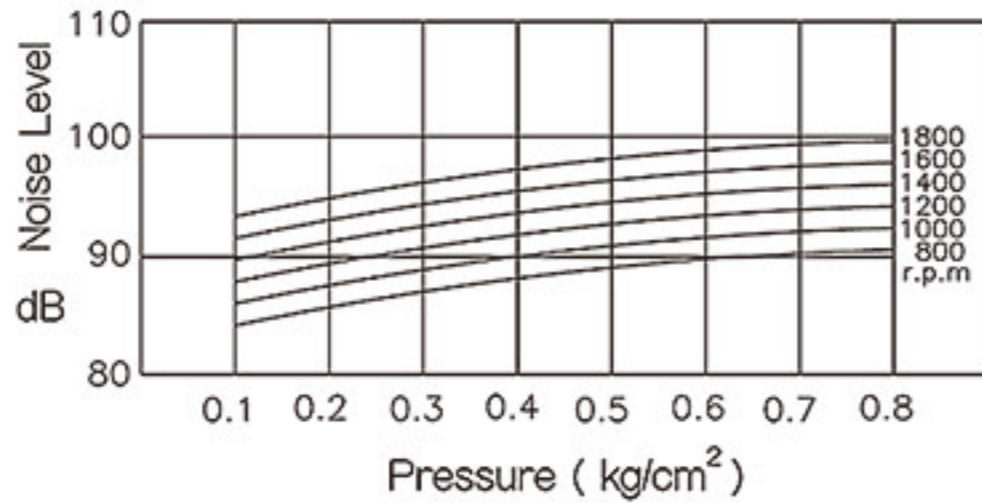

LT / LTV-200A

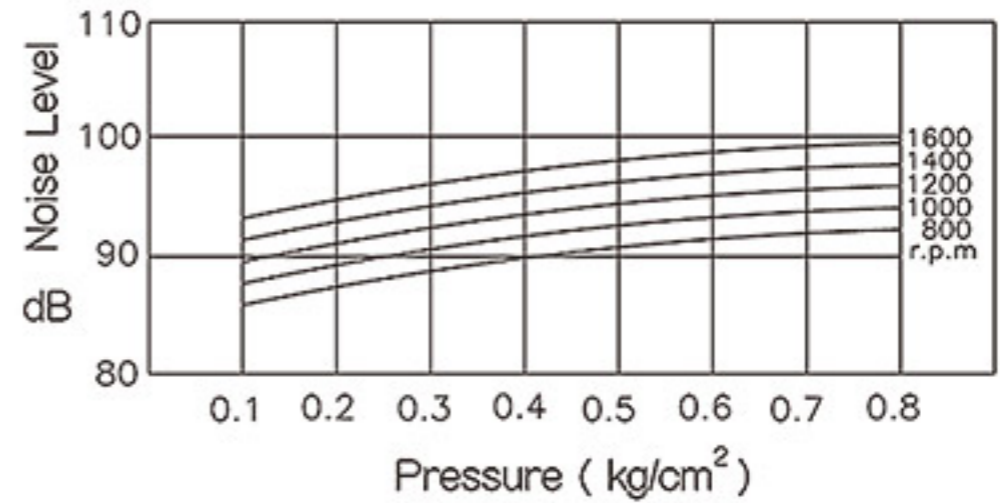

LT / LTV-250

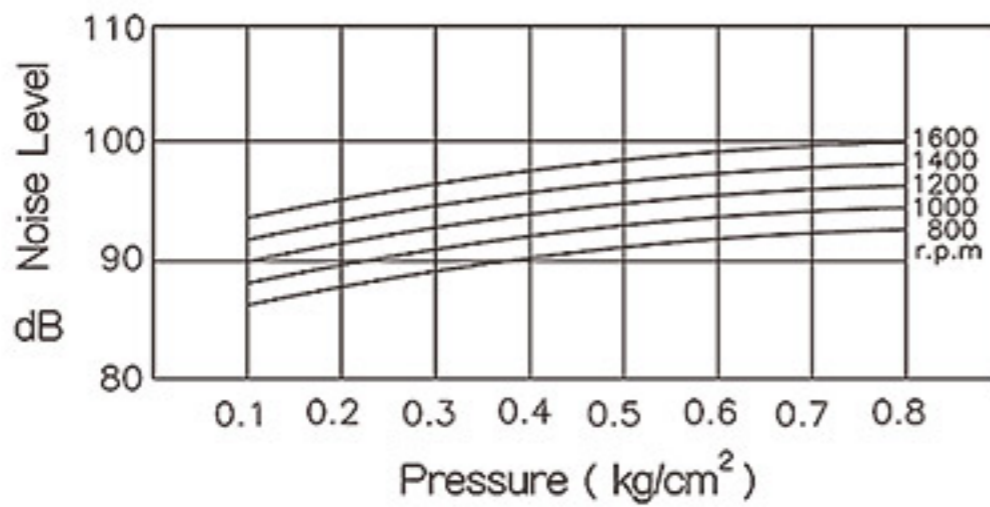

LT / LTV-300A

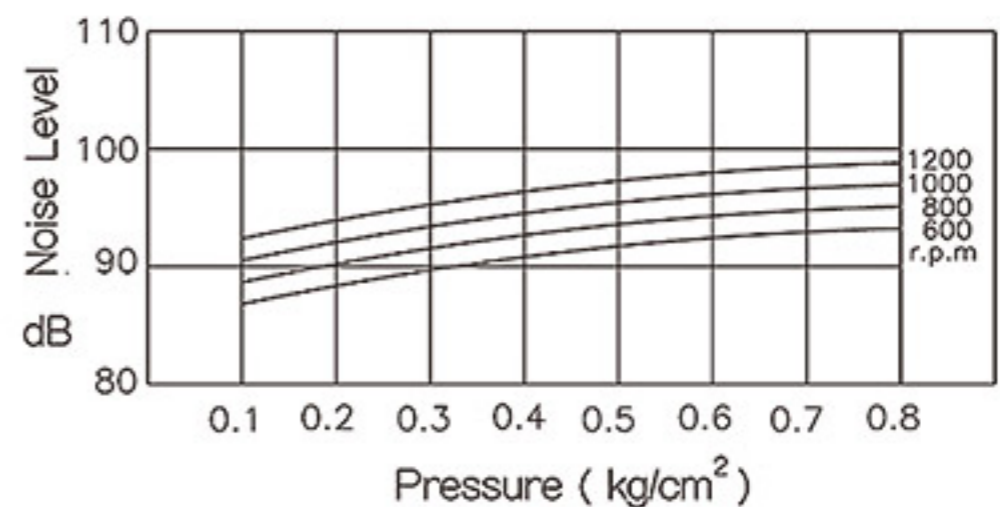

LT / LTV-250A

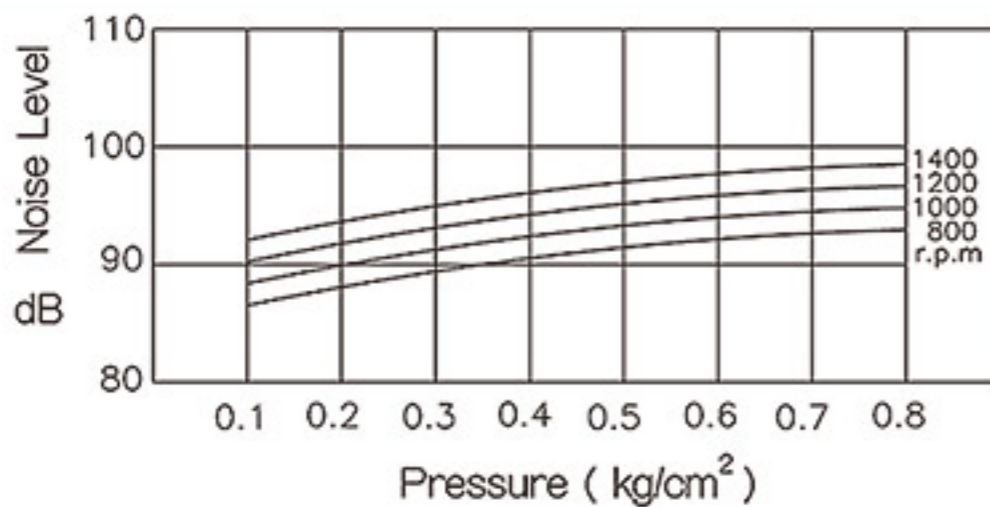

LT / LTV-350

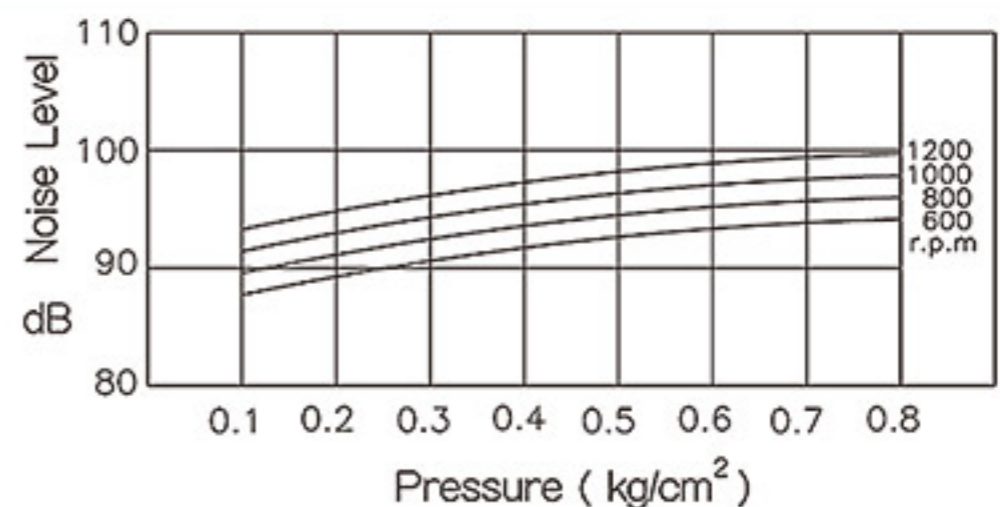

LT / LTV-300

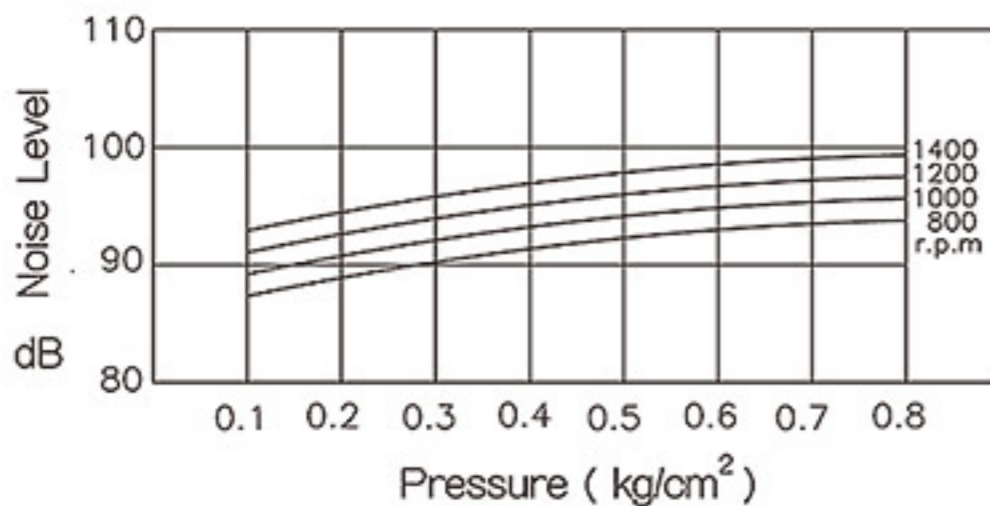

LT / LTV-400

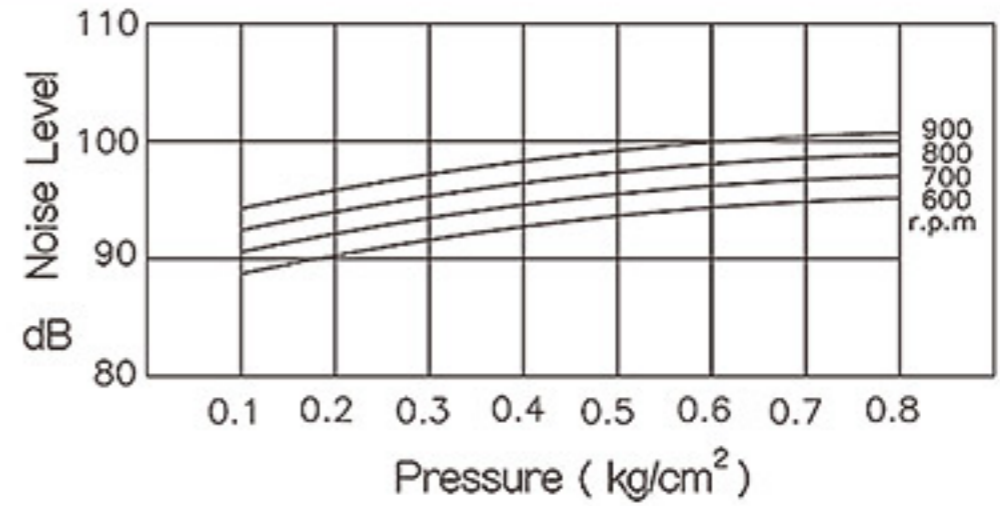

◆ | Noise level measured at distance 1 meter for the blower fitted with standard silenced

◆ | Noise level maybe different according to the extend pipe length and ambient condition

Structure & Material

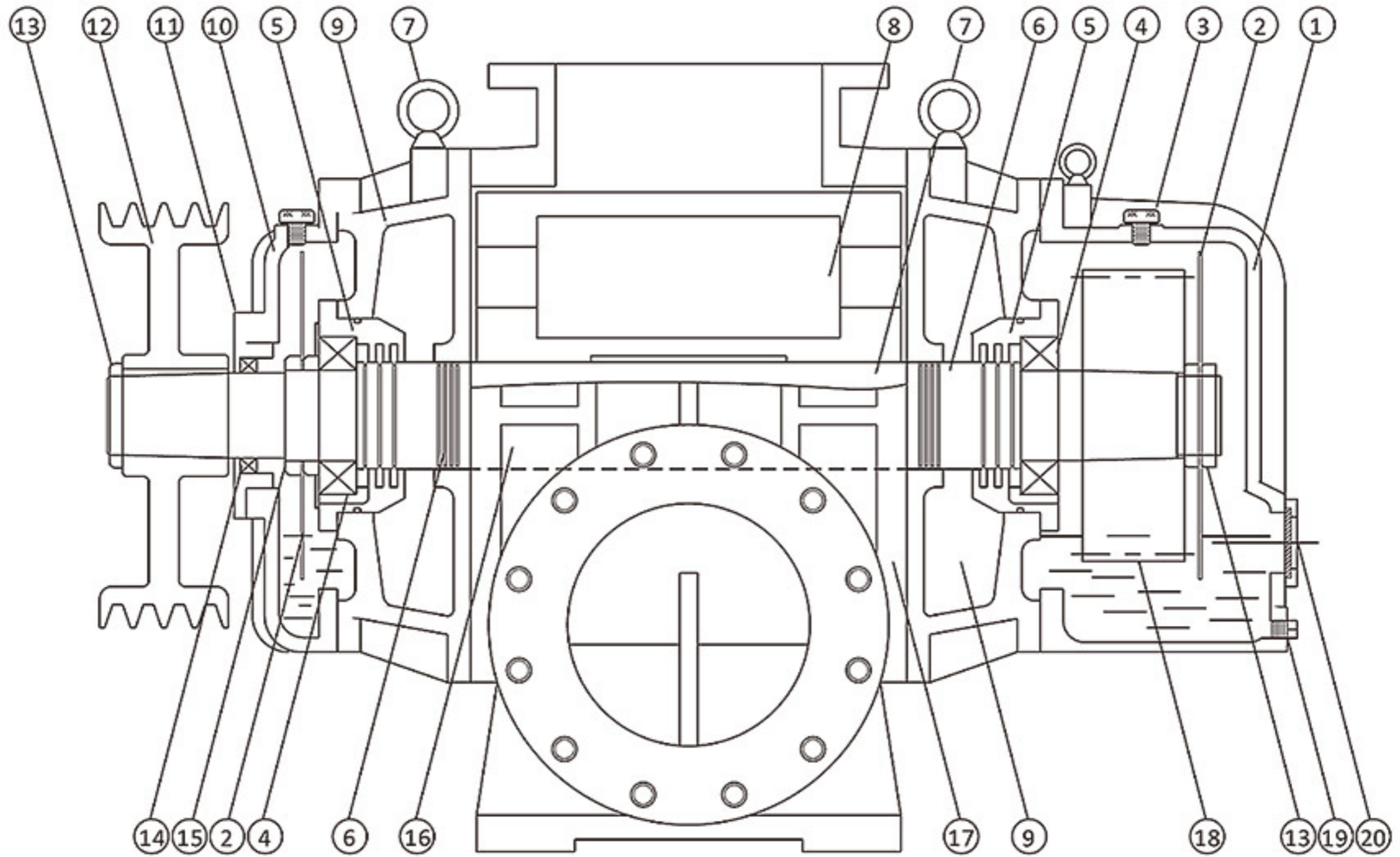

NO.	NAME	MATERIAL	NO.	NAME	MATERIAL
1.	Gear case	FC250	11.	Seal case	FC250
2.	Oil splash	SS400	12.	Pulley	FC250
3.	Oil plug	S45C	13.	Nut	SS400
4.	Bearing	SUJ2	14.	Seal	NBR
5.	Bearing case	FC250	15.	Nut	SS400
6.	Labyrinth seal	SS400	16.	Shaft	SCM440
7.	Eye bolt	S45C	17.	Main casing	FC250
8.	Rotor	FC250	18.	Timing gear	SCM415
9.	Side cover	FC250	19.	Oil drain	S45C
10.	Oil case	FC250	20.	Oil gauge	S45C

Dimensions and Weights

LT-025 ~ 040

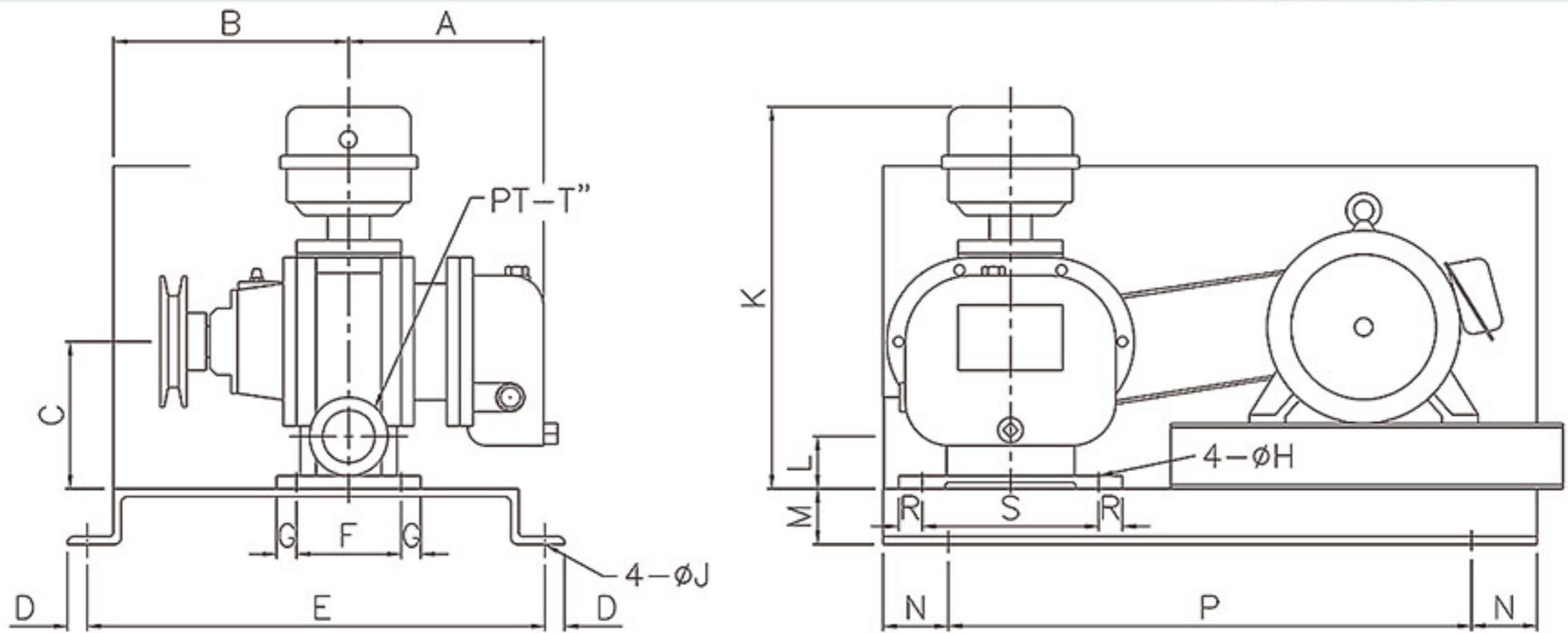

MODEL	A	B	C	D	E	F	G	H	J	K	L	M	N	P	R	S	T	Wt.(Kg)
LT-025	135	145	120	15	350	54	13	10	12	340	40	43	50	400	15	135	1	20
LT-040	162	185	120	15	350	80	15	10	12	340	40	43	50	400	15	135	1.5	25

UNITS : mm

◆ Wt.(kg): Main body weight

LT-050 ~ 065

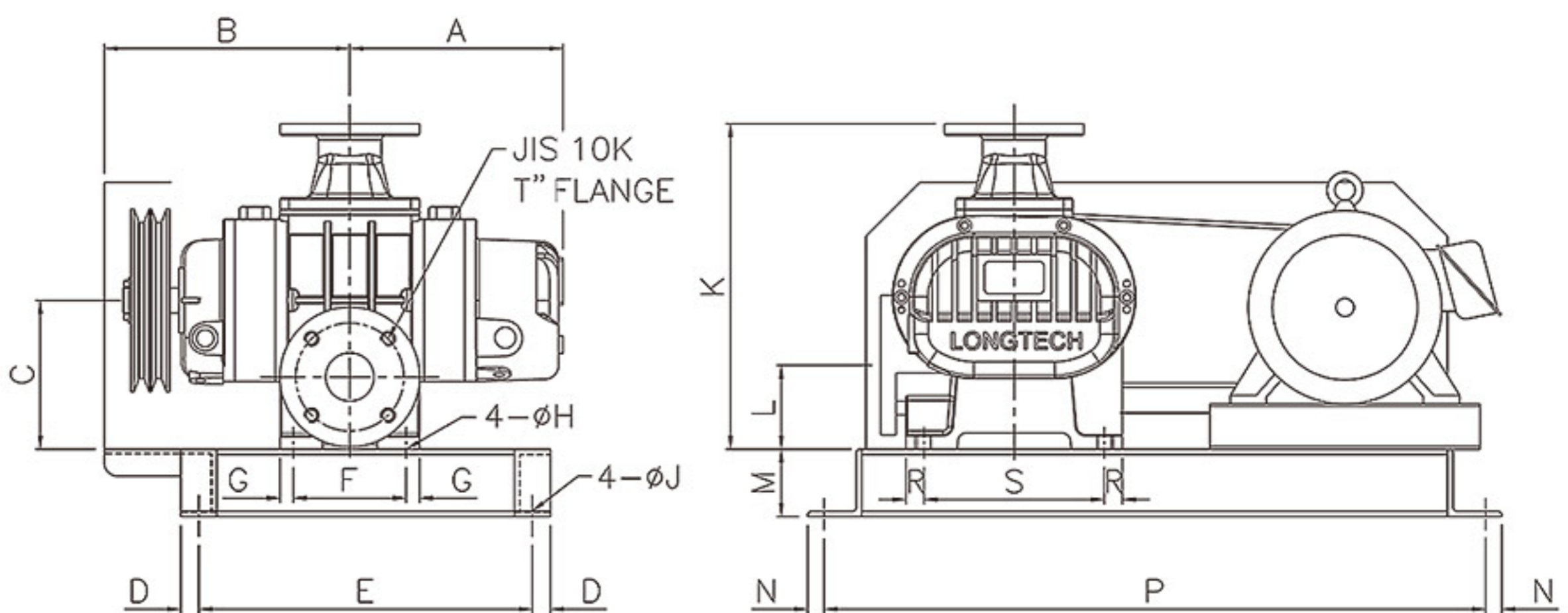

MODEL	A	B	C	D	E	F	G	H	J	K	L	M	N	P	R	S	T	Wt.(Kg)
LT-050	240	270	168	20	370	125	15	15	15	356	90	75	18	734	15	200	2	76
LT-065	280	290	173	20	370	210	15	15	15	356	95	75	18	734	15	200	2.5	94

UNITS : mm

◆ Wt.(kg): Main body weight

Dimensions and Weights

LT-080 ~ 150

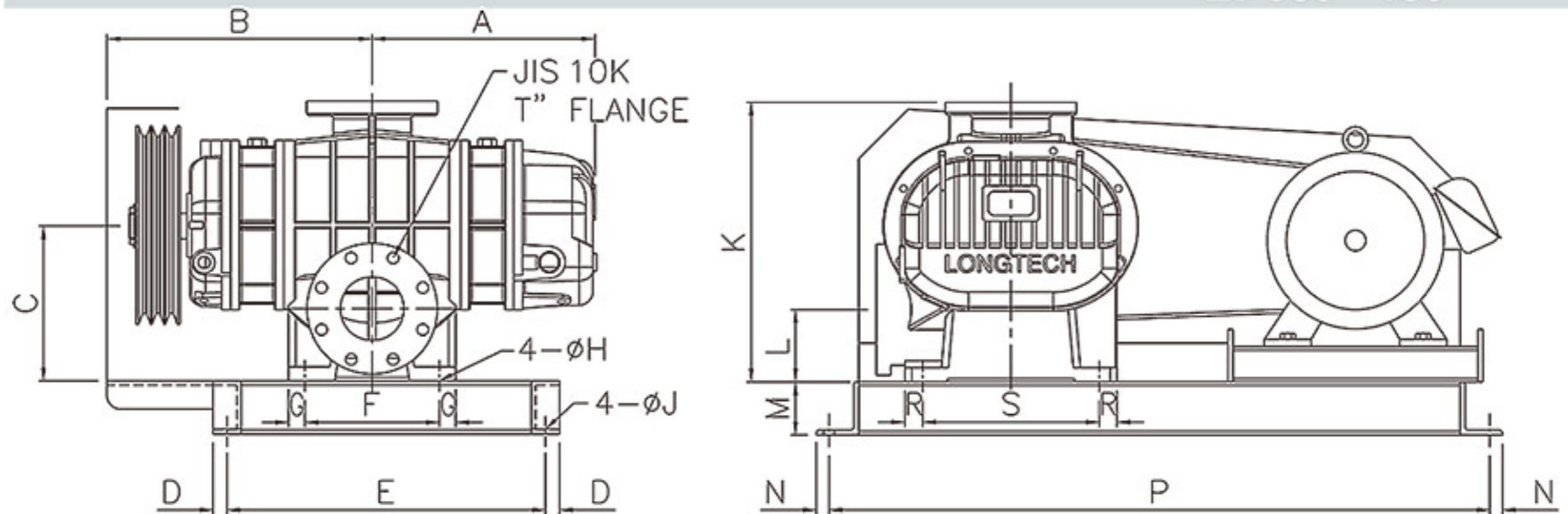

MODEL	A	B	C	D	E	F	G	H	J	K	L	M	N	P	R	S	T	Wt.(Kg)
LT-080	315	375	220	20	450	190	25	19	15	395	102	75	18	934	25	250	3	167
LT-100	365	425	220	20	450	290	25	19	15	395	115	75	18	934	25	250	4	193
LT-125S	405	445	265	25	605	230	25	19	19	475	145	100	20	1190	25	350	5	319
LT-125	445	485	300	25	605	320	25	19	19	515	155	100	20	1190	25	350	5	353
LT-150	500	540	300	25	605	425	25	19	19	515	155	100	20	1190	25	350	6	418

UNITS : mm
◆ Wt.(kg): Main body weight

LT-200 ~ 300

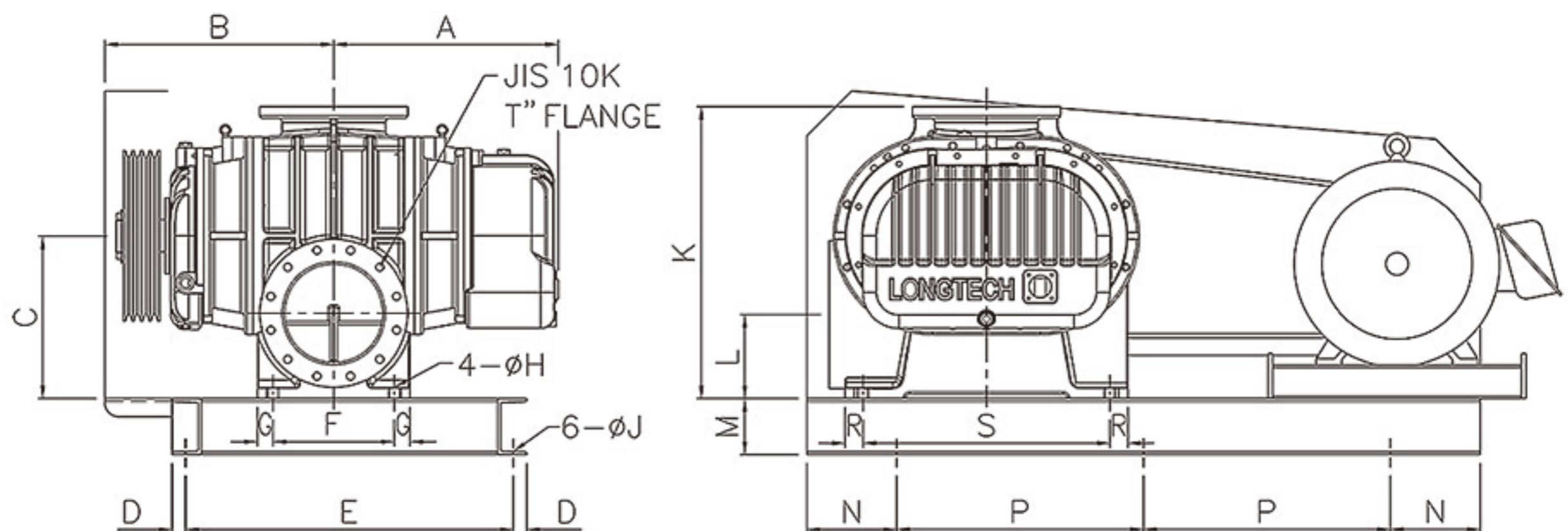

MODEL	A	B	C	D	E	F	G	H	J	K	L	M	N	P	R	S	T	Wt.(Kg)
LT-200	515	495	363	30	730	270	35	23	19	650	190	125	200	550	40	550	8	720
LT-250	605	595	388	30	730	460	35	23	19	675	225	125	200	550	40	550	10	913
LT-250A	778	678	500	40	850	650	65	27	24	875	250	200	200	800	55	620	10	1665
LT-300	900	805	500	40	1120	650	65	27	24	875	250	200	200	800	55	620	12	2010
LT-300A	954	840	505	40	1300	660	60	27	24	930	243	200	200	800	60	680	12	3200

UNITS : mm
◆ Wt.(kg): Main body weight

Dimensions and Weights

LT-350

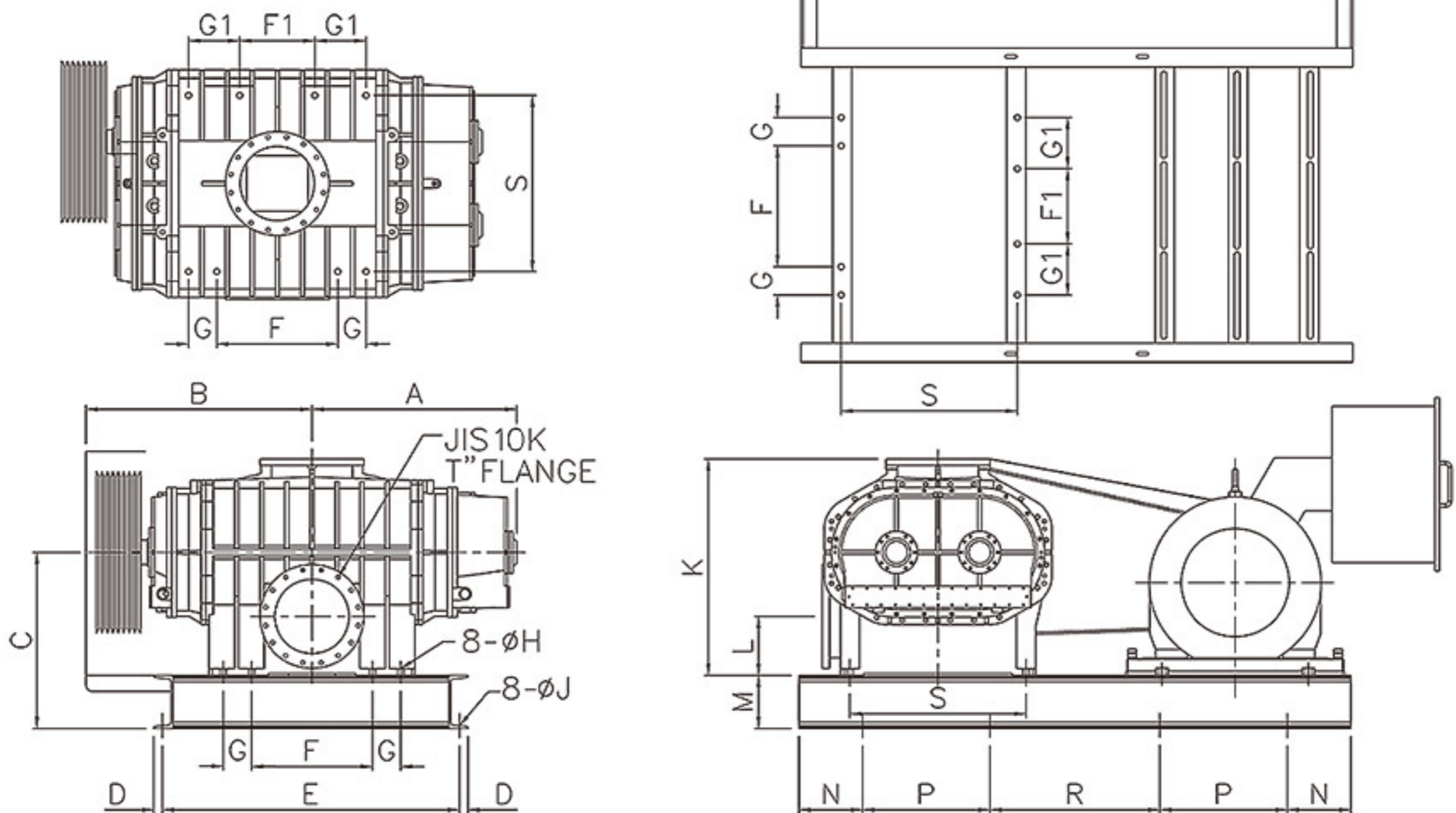

MODEL	A	B	C	D	E	F	F1	G	G1	H	J	K	L	M	N	P	R	S	T	Wt.(Kg)
LT-350	965	1065	830	40	1400	570	354	133	35	241	24	1020	278	250	300	600	800	830	14	4100

UNITS : mm
 ◆ Wt.(kg): Main body weight

LT-400

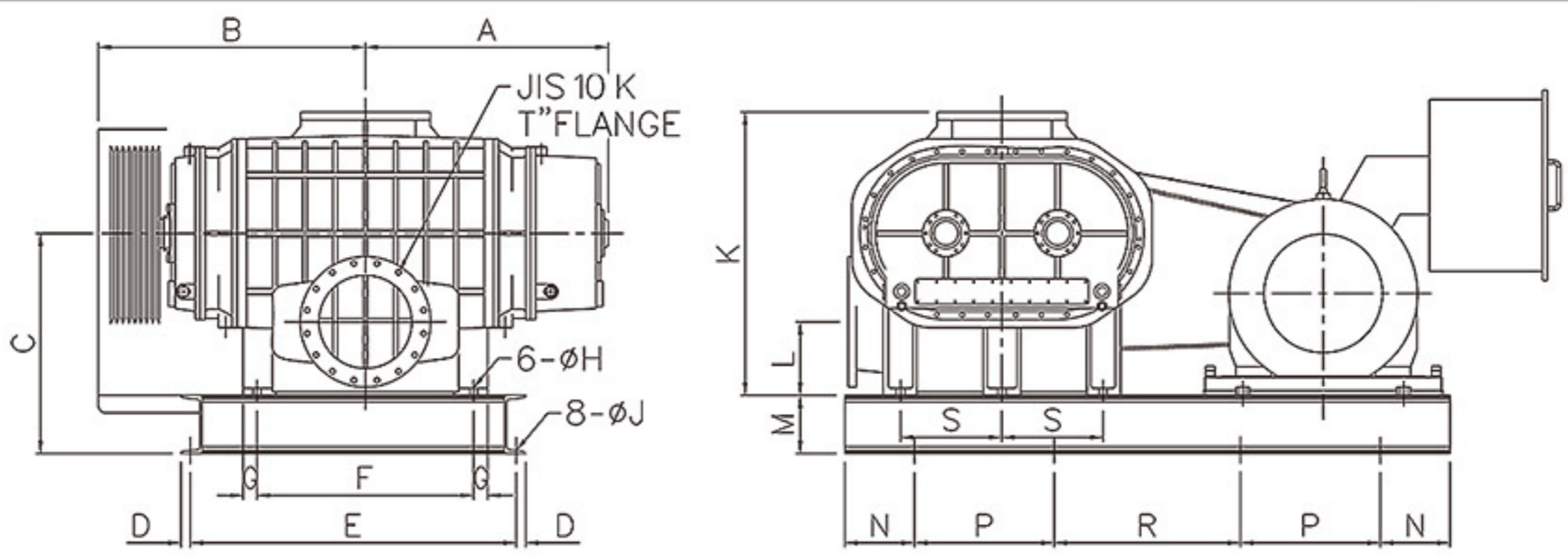

MODEL	A	B	C	D	E	F	G	H	J	K	L	M	N	P	R	S	T	Wt.(Kg)
LT-400	1043	1147	945	40	1400	930	60	35	24	1215	315	250	300	600	800	435	16	4650

UNITS : mm
 ◆ Wt.(kg): Main body weight

Accessories

OUTDOOR SILENCER

UNITS : mm

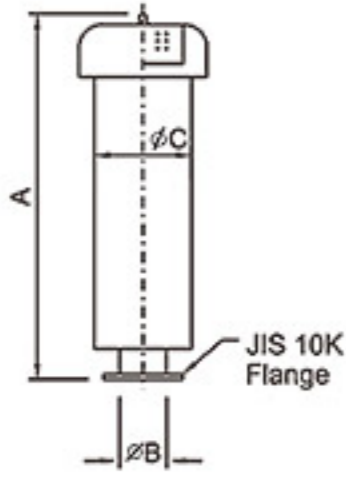

MODEL	A	B	C	SUITABILITY
O-050	680	50	165	LT-050
O-065	680	65	165	LT-065
O-080	800	80	216	LT-080
O-100	820	100	267	LT-100
O-125	1300	125	350	LT-125
O-150	1300	150	350	LT-150
O-200	2030	200	525	LT-200
O-250	2030	250	600	LT-250
O-300	2240	300	700	LT-300
O-350	2570	350	800	LT-350
O-400	2570	400	800	LT-400

INDOOR SILENCER

UNITS : mm

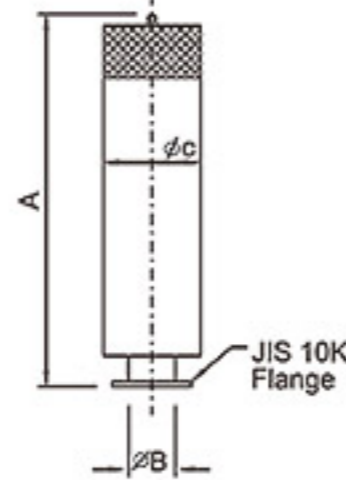

MODEL	A	B	C	SUITABILITY
I-050	680	50	165	LT-050
I-065	680	65	165	LT-065
I-080	800	80	216	LT-080
I-100	820	100	267	LT-100
I-125	1300	125	350	LT-125
I-150	1300	150	350	LT-150
I-200	2030	200	525	LT-200
I-250	2030	250	600	LT-250
I-300	2240	300	700	LT-300
I-350	2570	350	800	LT-350
I-400	2570	400	800	LT-400

DISCHARGE SILENCER

UNITS : mm

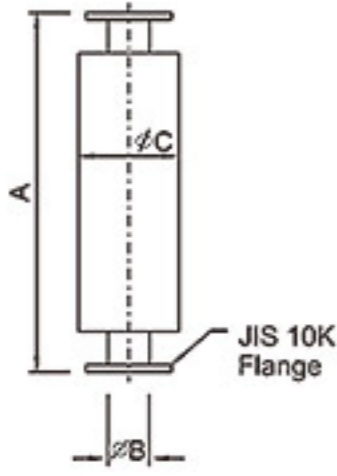

MODEL	A	B	C	SUITABILITY
D-050	660	50	165	LT-050
D-065	660	65	165	LT-065
D-080	760	80	216	LT-080
D-100	760	100	267	LT-100
D-125	1190	125	350	LT-125
D-150	1190	150	350	LT-150
D-200	1735	200	525	LT-200
D-250	1735	250	600	LT-250
D-300	1735	300	700	LT-300
D-350	2230	350	800	LT-350
D-400	2230	400	800	LT-400

HORIZONTAL SILENCER

UNITS : mm

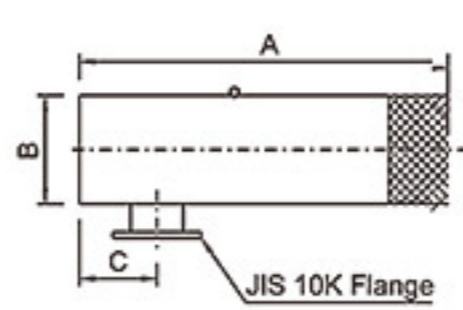

MODEL	A	B	C	SUITABILITY
RO-050	580	165	120	LT-050
RO-065	580	165	120	LT-065
RO-080	700	216	150	LT-080
RO-100	700	267	150	LT-100
RO-125	1200	350	150	LT-125
RO-150	1200	350	150	LT-150
RO-200	1880	525	400	LT-200
RO-250	1880	600	400	LT-250
RO-300	2090	700	400	LT-300
RO-350	2420	800	400	LT-350
RO-400	2420	800	400	LT-400

"T" JOINT

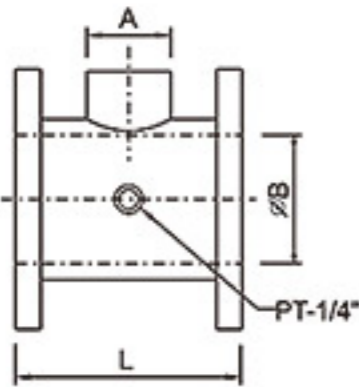

UNITS : mm

MODEL	A	B	C	SUITABILITY
T-050	40	50	150	LT-050
T-065	40	65	150	LT-065
T-080	40	80	165	LT-080
T-100	40	100	165	LT-100
T-125	50	125	205	LT-125
T-150	50	150	210	LT-150
T-200	50	200	265	LT-200

"T" JOINT

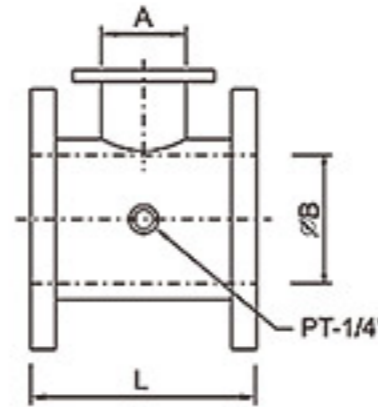

UNITS : mm

MODEL	A	B	L	SUITABILITY
T-250	80	250	295	LT-250
T-300	80	300	350	LT-300
T-350	125	350	400	LT-350
T-400	125	400	500	LT-400

RELIEF VALVE

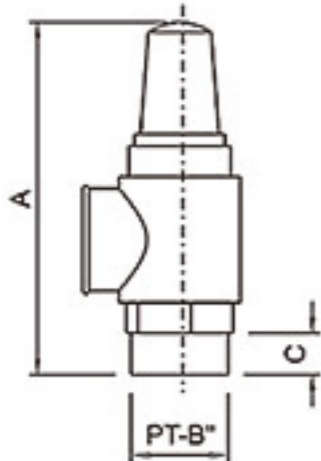

UNITS : mm

MODEL	A	B	C	SUITABILITY
R-038	132	1.5"	26	LT-050~100
R-050	150	2"	28	LT-125~200

RELIEF VALVE

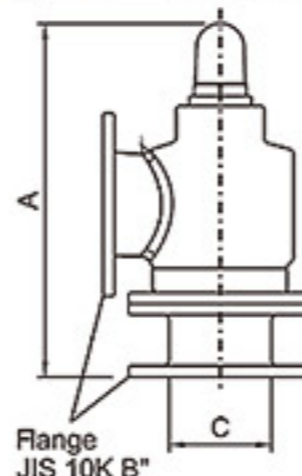

UNITS : mm

MODEL	A	B	C	SUITABILITY
R-080	485	3"	80	LT-250~300
R-125	485	5"	125	LT-350~400

FLEXIBLE JOINT

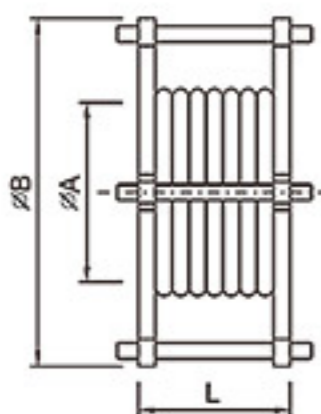

UNITS : mm

MODEL	A	B	L	SUITABILITY
JF-050	50	155	150	LT-050
JF-065	65	175	150	LT-065
JF-080	80	185	150	LT-080
JF-100	100	210	150	LT-100
JF-125	125	250	150	LT-125
JF-150	150	280	150	LT-150
JF-200	200	330	200	LT-200
JF-250	250	400	200	LT-250
JF-300	300	445	200	LT-300
JF-350	350	490	230	LT-350
JF-400	400	560	250	LT-400

FLEXIBLE JOINT

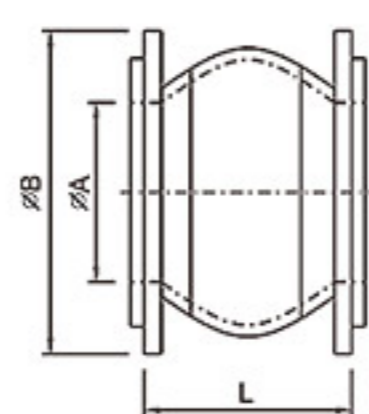

UNITS : mm

MODEL	A	B	L	SUITABILITY
F-050	50	155	105	LT-050
F-065	65	175	115	LT-065
F-080	80	185	130	LT-080
F-100	100	210	135	LT-100
F-125	125	250	170	LT-125
F-150	150	280	180	LT-150
F-200	200	330	205	LT-200
F-250	250	400	240	LT-250
F-300	300	445	260	LT-300
F-350	350	490	265	LT-350
F-400	400	560	265	LT-400

Accessories

SHORT SILENCER

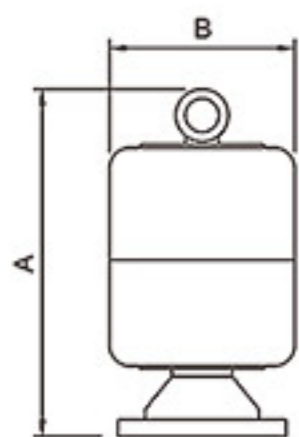

UNITS : mm

MODEL	A	B	SUITABILITY
S-50	320	176	LT-50
S-65	320	176	LT-65

90° ELBOW

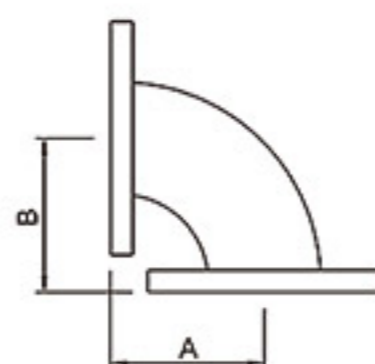

UNITS : mm

MODEL	A	B	SUITABILITY
HE-050	83	121	LT-050
HE-065	103	103	LT-065
HE-080	122	122	LT-080
HE-100	160	160	LT-100
HE-125	199	199	LT-125
HE-150	237	237	LT-150
HE-200	313	313	LT-200
HE-250	389	389	LT-250
HE-300	465	465	LT-300
HE-350	541	541	LT-350
HE-400	618	618	LT-400

FILTER TANK

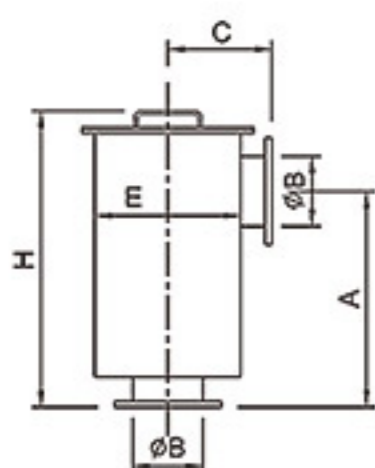

UNITS : mm

MODEL	A	B	C	E	H
B-050	395	50	180	210	530
B-065	395	65	180	210	530
B-080	480	80	210	270	670
B-100	480	100	210	270	670

FILTER TANK

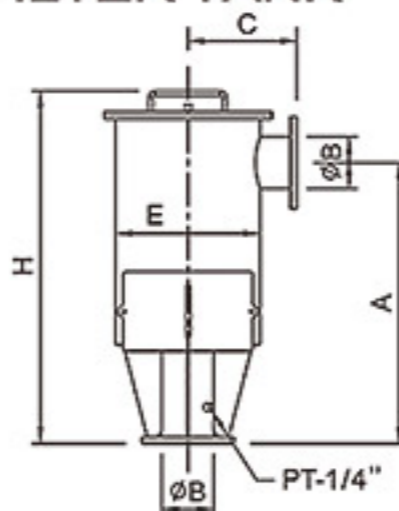

UNITS : mm

MODEL	A	B	C	E	H
B-125	760	125	270	330	770
B-150	760	150	270	330	770
B-200	920	200	370	492	1140
B-250	1092	250	358	492	1340
B-300	1200	300	420	612	1540
B-350	1300	350	515	777	1645
B-400	1300	400	515	777	1645

CHECK VALVE

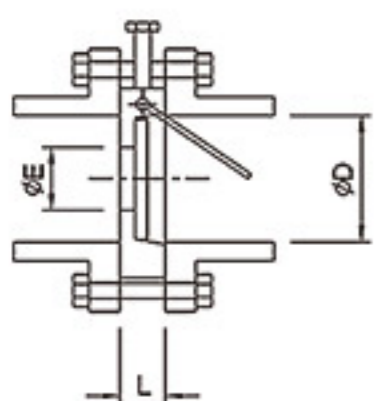

UNITS : mm

MODEL	D	E	L	SUITABILITY
C-050	50	30	17	LT-050
C-065	65	45	19	LT-065
C-080	80	55	20	LT-080
C-100	100	70	20	LT-100
C-125	125	90	23	LT-125
C-150	150	110	24	LT-150
C-200	200	140	28	LT-200
C-250	250	190	28	LT-250

DUAL CHECK VALVE

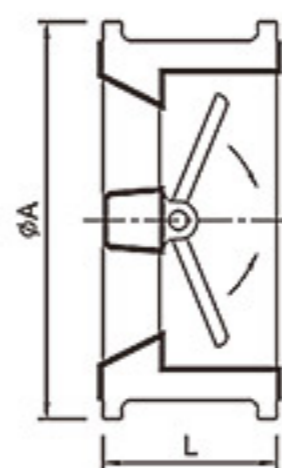

UNITS : mm

MODEL	A	L	SUITABILITY
DC-200	270	127	LT-200
DC-250	332	146	LT-250
DC-300	377	181	LT-300
DC-350	420	184	LT-350
DC-400	483	191	LT-400

LIQUID FILLED PRESSURE GAUGE

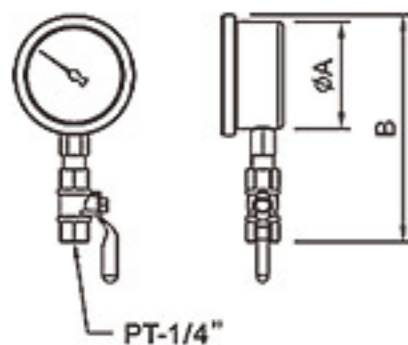

UNITS : mm

MODEL	A	B	SUITABILITY
AC-A	63	133.5	LT-50~400
壓力範圍	76~0cmHg, 0~1kg/cm ²		

TUBE CONNECTOR

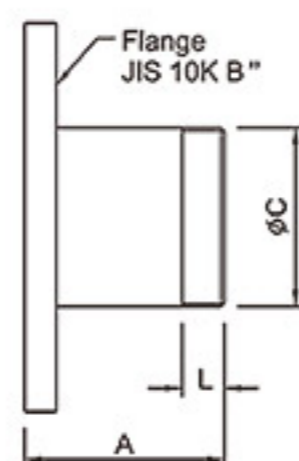

UNITS : mm

MODEL	A	B	C	L	SUITABILITY
V-050	95	2"	50	40	LT-050
V-065	95	2.5"	65	40	LT-065
V-080	95	3"	80	40	LT-080
V-100	95	4"	100	40	LT-100
V-125	155	5"	125	50	LT-125
V-150	155	6"	150	50	LT-150
V-200	155	8"	200	60	LT-200
V-250	155	10"	250	60	LT-250
V-300	155	12"	300	60	LT-300
V-350	160	14"	350	70	LT-350
V-400	160	16"	400	70	LT-400

ABSORBER

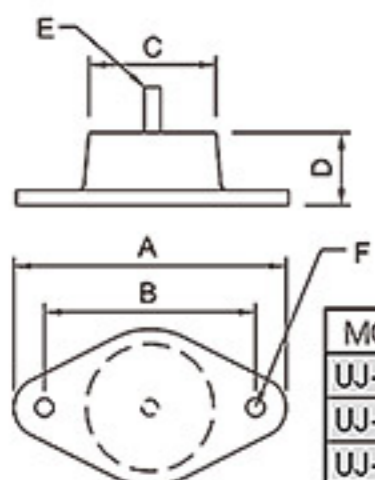

UNITS : mm

MODEL	A	B	C	D	E	F	SUITABILITY(Kg)
UJ-200J	142	110	65	55	3/8"	Ø12	0~150
UJ-500J	214	166	100	57	1/2"	Ø14	140~450
UJ-800J	285	220	130	80	1/2"	Ø17	400~750

ABSORBER

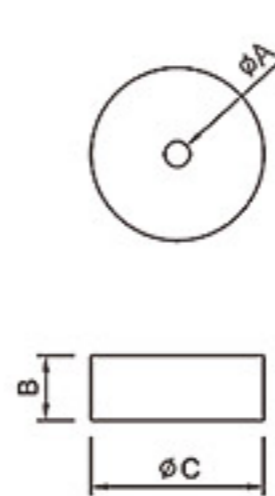

UNITS : mm

MODEL	A	B	C	D	E	F
LT-040	15	25	50			
LT-050~065	15	25	75			
LT-080~100	25	39	102			
LT-125~400				101	147	10



LONGTECH ROOTS BLOWER

ROOTS TYPE BLOWER & VACUUM PUMP **CATALOG**



ISO 9001 Certificate

LONGTECH MACHINERY INDUSTRY CO.,LTD.

COMPANY : NO.23 , LANE 470 , NANSHAN RD. , SEC.2 ,
LUCHU HSIANG , TAOYUAN HSIEN , TAIWAN. R.O.C .

TEL. : 886-3-324-2370

FAX. : 886-3-324-0219

http : //www.rootsblower.com.tw

E-mail : aero-tech@umail.hinet.net