

AIRFIN

Diffused Aeration System

PRODUCT CATALOGUE

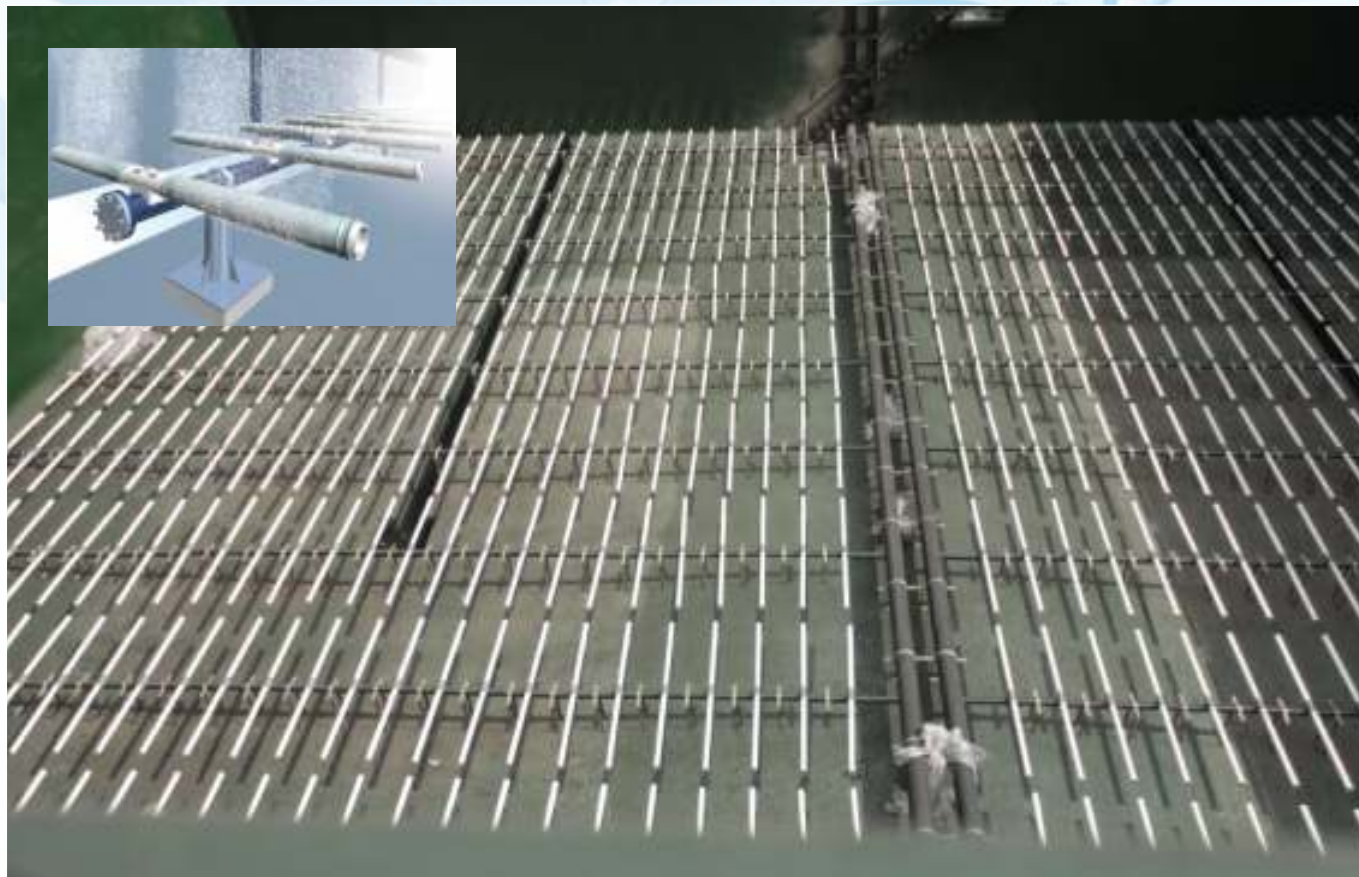



ABOUT US ■

Leading manufacturer of aeration system and biological treatment equipment. Reliable, High quality control products with over 20 years of experience. Complete solution for Municipal, industrial and private waste water treatment plants. Design, supply and service of complete aeration systems and products. More than 1,000,000 units and 3000 installations at various sites in India and abroad working satisfactorily. Strong distributor network throughout India and overseas for clients, consultants and OEMs. Suitable for newly developed treatment plants, upgrades of existing facilities or maintenance. Well-equipped in-house testing facilities for our products. Meet ASCE standards for SOTR, SOTE, DO, air discharge and head loss etc....

Company Certified by ISO 9001:2015.

ABOUT AIRFIN® ■

- EPDM/Silicon and other specially compounded material
- Heavy duty full membrane support non - corrosive accessories
- Maximum oxygen transfer efficiency 0.60, 1.0, 1.2 mm pore size available
- Backflow prevention features
- Buoyant/Non buoyant designs
- Maximum life expectancy @7 -8 years with Regular cleaning frequency
- Material properties tested by CIPET
- Mechanical/chemical cleaning system for clogged diffusers
- Factory assembled diffuser for ease of operation
- System expandability in field without special tools requirement
- Partial / complete replacement systems
- Self purging system
- Fixed / floating(retrievable) design
- Light weight for ease of installation

PROCESS ■

In the waste water treatment process, aeration, to be effective must transfer oxygen to the liquid for use by microorganism, to produce a floc and mixing the liquor. Diffused aeration is effective method for aeration by means of porous diffusers installed at the bottom of the tank. In the aeration process oxygen transfer takes place by molecular diffusion through the interface film between air and liquid and it increases in proportion to the interface area. For a given airflow, as the number of bubbles increases, the surface area increases and the rise velocity of bubbles decreases, the diffused aeration transfers more oxygen to the liquid than mechanical aeration, e.g.: diffuser emerging up to 2mm bubbles presents six times more surface area to the liquid than surface aerator emitting 10-12 mm bubbles, also rise velocity of bubbles is lower. Surface area and rise velocity of bubbles contribute to the higher oxygen transfer capacity of diffused aeration system.

BENEFITS ■

- High oxygen transfer efficiency results in more BOD removal per unit of energy.
- Compatible with any basin or tank configuration and geometry.
- Permits deeper tanks and saving more land requirement.
- Gives uniform distribution of dissolved oxygen all over the tank.
- The supply of air volume can be adjusted according to biological loads and flow.
- Adaptability of the system to existing pneumatic circuits eliminates the need for additional air generators.
- Can be used to retrofit existing aeration system.
- Minimum piping for ease of installation and maintenance.
- Purging of diffuser is not required.
- Low investment and operation cost, with minimum and easy maintenance.

AREA OF APPLICATION ■

The system can be used in various types of aeration process like....

- Activated sludge system.
- Oxidation pond (stabilization pond)
- Aerated lagoons
- Aerobic digester units
- Intermittent (on/off) aeration Blending liquids

Special Industrial Applications like....

- Electroplating technology
- Stripping gases
- Blending liquids

APPLICABLE INDUSTRIES ■

- Municipal Waste water treatment
- Sewage treatment plant
- Pharmaceutical industries
- Pulp and paper industries
- Food and beverages industries
- Chemical industries
- Leather industries
- Textile industries
- Aqua culture process etc....

AIRFIN®
Diffused Aeration System

FINE BUBBLE TUBULAR DIFFUSER ■

AIRFIN® Tubular Diffusers are designed to handle high volumetric air discharge with ease. Our Diffuser Membranes are specially formulated to handle high pressure air discharge without stressing the membrane and comes with perforations that are MICROSTRESS Resistant Technology™ that significantly lessens rupture in membranes even in above average conditions and prevent back flow and simultaneously providing higher oxygen transfer efficiency. Its sturdy structural design prevents diffuser damage during and before use.

TYPES OF MEMBRANE MATERIAL ■

AIRFIN® Tubular Diffusers Membranes comes with choice of membrane material to better fit different usage conditions.

- EPDM (ethylene propylene diene monomer)- "EPNOL": Manufactured with high grade Dupont™ Rubber Technology with low plasticizer content and quality in mind. These membranes are suitable for most municipal and industrial application such as waste water treatment plants.
- Silicon - "SILCOX" : Made using specially crafted and industry leading Dow Corning™ Silicon with unparalleled quality. Our silicon membranes are suitable for application where fouling and chemical oxidation due to solvent exposure, High temperatures occur and specific chemical compatibilities are required. Outperforming others in durability and elasticity making it a very sought-after product.
- Viton® : Suitable for applications where resistivity to most chemicals and foulants is required. Our Viton® membranes although not cost effective have been proven to be an excellent choice to such applications.
- PU(Polyurethane) - "TPU": Our PU membranes are used in applications where EPDM are not a feasible option due to presence of hydrocarbon oils and aromatic solvents and are generally used in industrial waste treatments such as pulp and paper, food processing application etc.

MATERIAL AND MECHANICAL PROPERTIES FOR EPDM AND SILICON TUBULAR DIFFUSER

Mechanical Parameters	EPDM	SILICON
Material Make up	Polymer 20-22% Carbon Black 45-50% Plasticizer 22-23% Others 3%	Polymer 99% Colour additives 0.1%
Colour	black	Opaque white Milky white Aqua blue
Wall Thickness	1.8 ± 0.2 mm overall	1.8 ± 0.2 mm overall
Hardness (ASTM D-2240)	45 ± 6 shore "A" 50 ± 6 shore "A"	60 ± 5 shore "A" 50 ± 5 shore "A"
Tensile strength at break -KG/CM ² (ASTM D - 412)	99 kg/cm ²	90 kg/cm ²
Elongation at break (ASTM D - 412)	400%	900%
Tear strength "die-T" (ASTM D - 624)	7.5 N/mm	9 N/mm
Environmental Resistance Test		
Ozone resistance 75hrs, 40°C, 50mPa partial Ozone Pressure Non-cracking (ASTM D 1171 - 94)	Pass	Pass
Low Temp. property -40°C, Non brittle (ASTM D 832 - 92)	Pass	Pass
Density	1.2 g/cm ³ ± 0.5	1.25 g/cm ³ ± 0.5
MAX. Operating Air Temperature °C	60	95



"EPNOL" Standard Low Plasticizer EPDM Membrane ■

EPDM is an ethylene propylene diene monomer extruded membrane product and "EPNOL" is proprietary material compounding code with DOW CORNING/JSR/DUPONT(world leader in advanced rubber technology) raw material.

EPDM is a synthetic rubber which is custom moulded /specially blended for this application. The compound formulation and moulding/extruding technique are critical to ensure that the membrane maintains its physical properties over a long period of time, resists tearing, retains its shape even after years of continuous or cyclical use, produces fine bubbles, all at a minimal head pressure. Our EPDM membranes are field tested in municipal and industrial applications with excellent results. However standard EPDM is not recommended in cases where solvents, fats oils or greases, or high concentrations of metal salts are present in effluent.

"SILCOX" Silicon Membrane ■

"SILCOX" Silicon Membrane

"SILCOX"-SILICON is silicon extruded/moulded membrane product and "SILCOX" is proprietary material compounding codewith DOW CORNING-DUPONT(world leader in advanced rubber technology) raw material.

Silicone material for plants which had potential problems with membrane failure such as fouling or chemical oxidation of rubber due to solvent exposure. silicone have a tendency over time to suffer from tearing due to flexure failure, which is something that does not significantly afflict EPDM membranes. Silicone is suited to cyclical operation, and does not offers a cost benefit over EPDM membranes.

AIRFIN 600 ■

Specifications:

Size	: 65 x 620 mm / 2.6 x 24"
uPVC/PP support pipe OD	: 63 mm
Membrane ID	: 63 mm
Perforation length	: 600 mm
Min active surface area	: 0.1 m ²
Air flow range/diffuser	: 2 - 7.5 m ³ / hr
Standard Design Flow	: 5 m ³ /hr
Perforation size	: 0.65 / 1 / 1.2 mm
No. of perforations	: ≈ 8435 Perforations
Bubble size	: 0.75 - 1.9 mm
Max. allowable air pressure	: 1.5Kg/cm ²
Max. permissible tank depth	: 9 m
Oxygen transfer per diffuser (SOTR) SAE in O ₂ Kg / Kw /hr	: up to 3
Connection size	: ¾ BSP male
Working area	: 0.3 - 1 m ²
Weight	: 1 Kg



Standard oxygen transfer efficiency (SOTE) and headloss for AIRFIN-600 performance

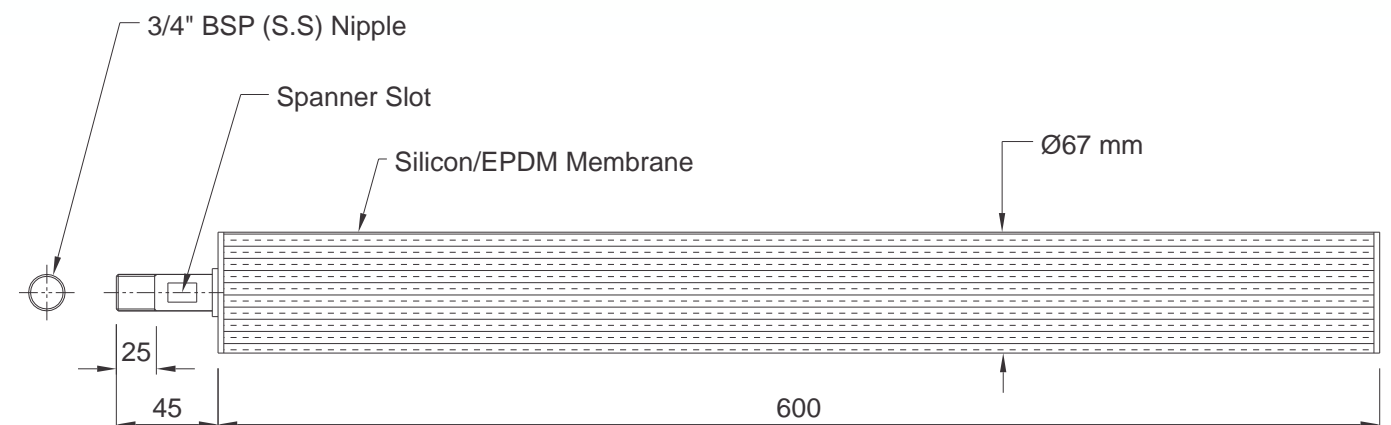
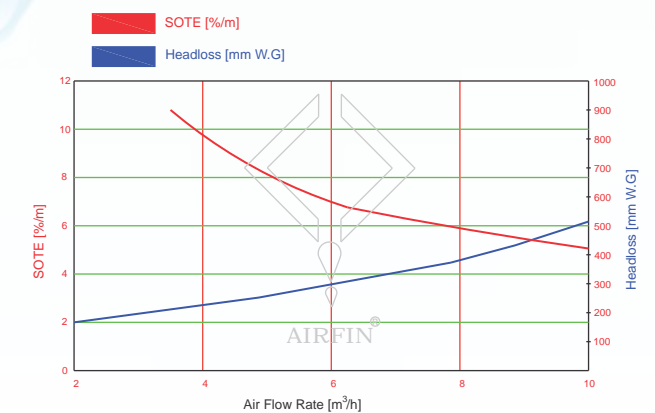

AIRFIN 1 ■

Specifications:

Size	: 65 x 1020 mm / 2.6 x 40"
uPVC/PP support pipe OD	: 63 mm
Membrane ID	: 63 mm
Perforation length	: 1000 mm
Min active surface area	: 0.18 m ²
Air flow range/diffuser	: 2 - 10 m ³ / hr
Standard Design Flow	: 7.5 m ³ /hr
Perforation size	: 0.65 / 1 / 1.2 mm
No. of perforations	: ≈ 14080 Perforations
Bubble size	: 0.75 - 1.9 mm
Max. allowable air pressure	: 1.5Kg/cm ²
Max. permissible tank depth	: 9 m
Oxygen transfer per diffuser (SOTR) SAE in O ₂ Kg / Kw /hr	: up to 4
Connection size	: ¾ BSP male
Working area	: 0.4 - 1.5 m ²
Weight	: 1.8 Kg



Standard oxygen transfer efficiency (SOTE) and headloss for AIRFIN-1 (65x1020mm) performance

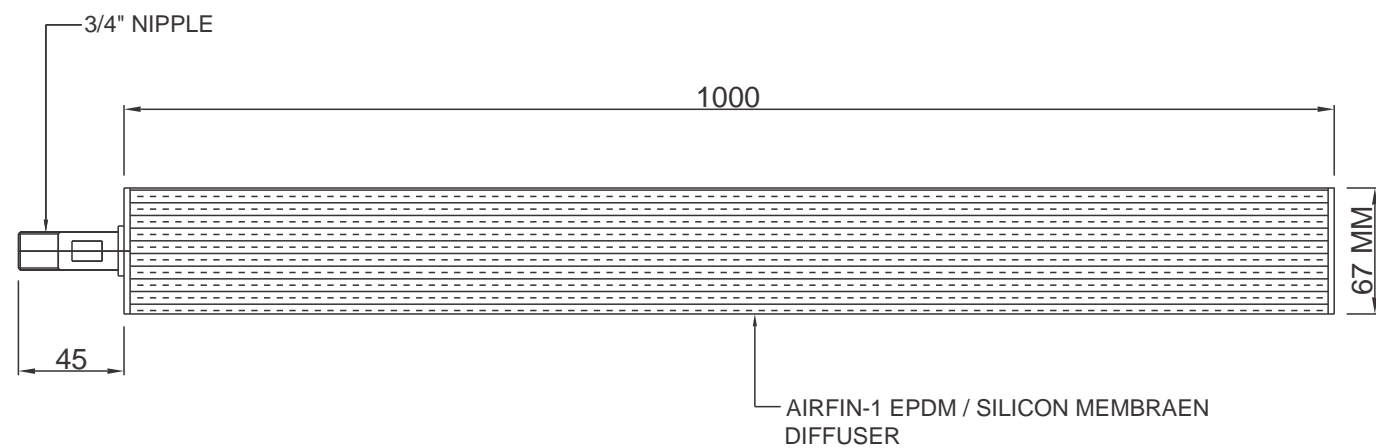
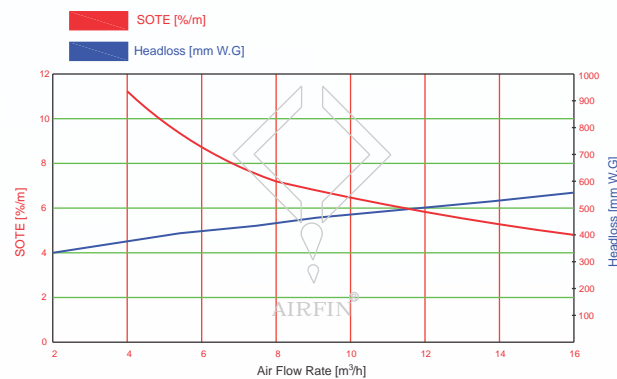

AIRFIN 1- HUB-2200 ■

Specifications:

Size	: 65 x 2200 mm / 2.6 x 80"
uPVC/ABS support pipe OD	: 63 mm
Membrane ID	: 63 mmX2 NOS
Perforation length	: 2000 mm
Min active surface area	: 0.36 m ²
Air flow range/diffuser	: 2 - 20 m ³ / hr
Standard Design Flow	: 12 m ³ /hr TO 16 m ³ /hr Max.
Perforation size	: 0.65 / 1 / 1.2 mm
No. of perforations	: ≈ 28200 Perforations
Bubble size	: 0.75 - 1.9 mm
Max. allowable air pressure	: 1.5Kg/cm ²
Max. permissible tank depth	: 9 m
Oxygen transfer per diffuser (SOTR) SAE in O ₂ Kg / Kw /hr /mtr	: up to 4
Working area	: 0.4 - 3.5 m ²
Weight	: 4.3 Kg

Standard oxygen transfer efficiency (SOTE) and headloss for AIRFIN-1 (65x1020mm) performance

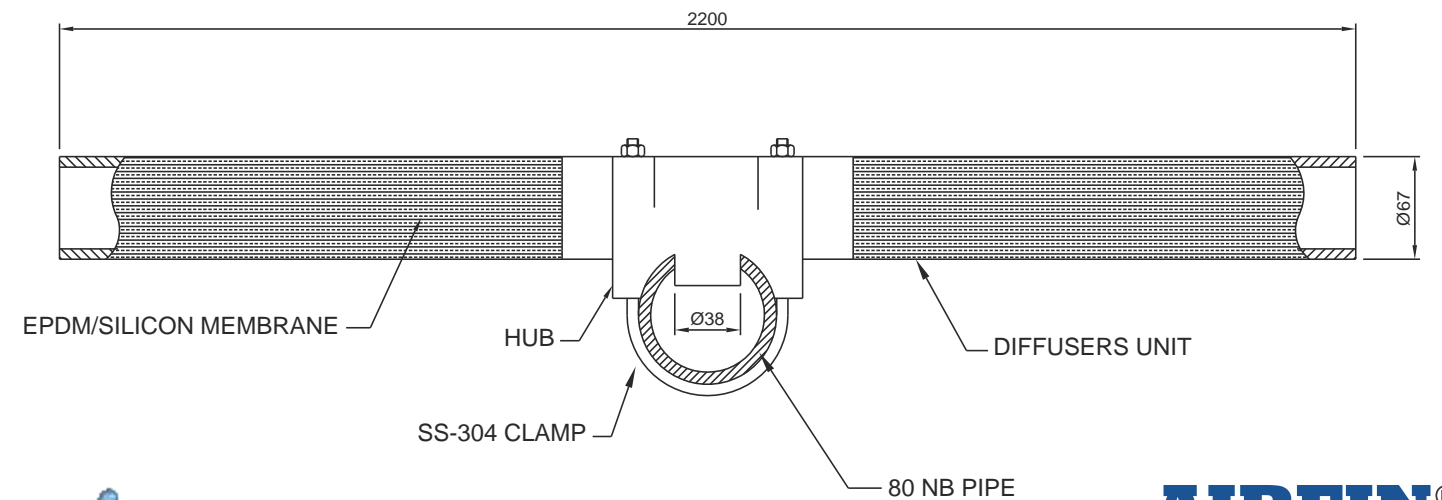
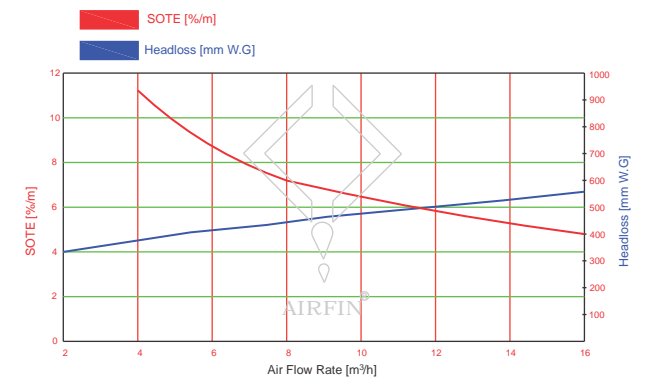

AIRFIN 2 ■

Specifications:

Size	: 80 x 1020 mm / 3.15 x 40"
uPVC support pipe OD	: 75 mm
Membrane ID	: 75 mm
Perforation length	: 1000 mm
Min active surface area	: 0.225 m ²
Air flow range/diffuser	: 2 - 12 m ³ / hr
Standard Design Flow	: 10 m ³ /hr
Perforation size	: 0.65 / 1 / 1.2 mm
No. of perforations	: ≈ 19500 Perforations
Bubble size	: 0.75 - 1.9 mm
Max. allowable air pressure	: 1.5Kg/cm ²
Max. permissible tank depth	: 9 m
Oxygen transfer per diffuser (SOTR) SAE in O ² Kg / Kw /hr	: up to 4.21
Connection size	: ¾ BSP male
Working area	: 0.75 - 2.5 m ²
Weight	: 2.2 Kg



Standard oxygen transfer efficiency (SOTE) and headloss for AIRFIN-3 (92x1020mm) /AIRFIN-2 (80x1020mm performance)

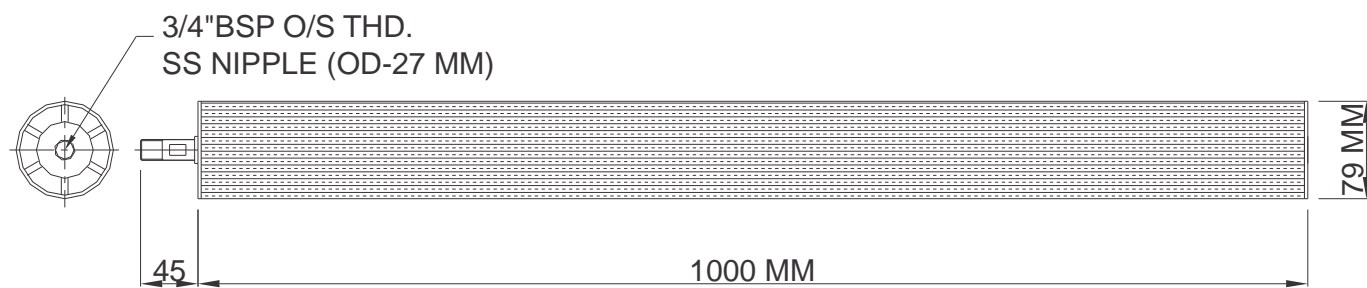
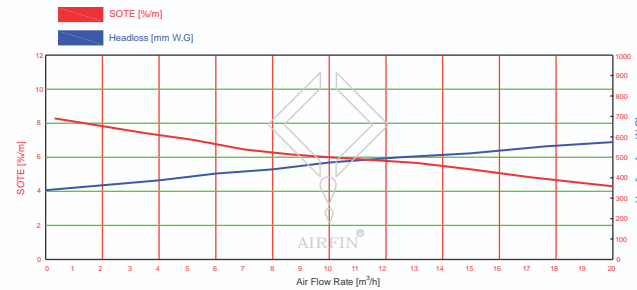

AIRFIN 3 ■

Specifications:

Size	: 92 x 1020 mm / 3.6 x 40"
uPVC support pipe OD	: 90 mm
Membrane ID	: 90 mm
Perforation length	: 1000 mm
Min active surface area	: 0.251 m ²
Air flow range/diffuser	: 2 - 15 m ³ / hr
Standard Design Flow	: 11 m ³ /hr
Perforation size	: 0.65 / 1 / 1.2 mm
No. of perforations	: ≈ 22500 Perforations
Bubble size	: 0.75 - 1.9 mm
Max. allowable air pressure	: 1.5Kg/cm ²
Max. permissible tank depth	: 9 m
Oxygen transfer per diffuser (SOTR) SAE in O ² Kg / Kw /hr	: up to 4.32Kg / Kw /hr
Connection size	: ¾ BSP male / 1" BSP
Working area	: 1 - 3 m ²
Weight	: 2.5 Kg



Standard oxygen transfer efficiency (SOTE) and headloss for AIRFIN-3 (92x1020mm) /AIRFIN-2 (80x1020mm performance)

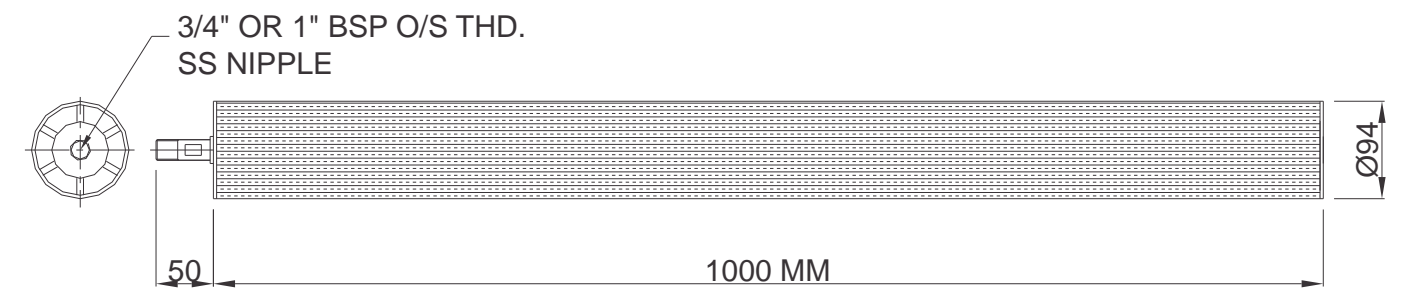
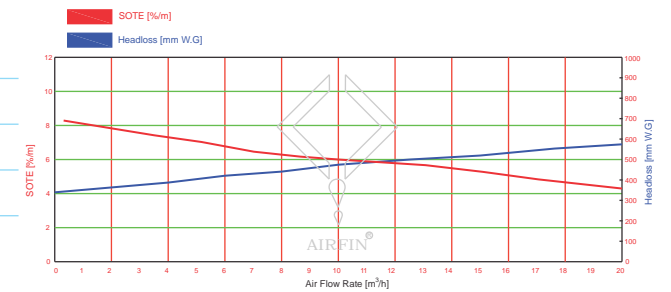

AIRFIN Vertical Membrane Diffuser VMD - 250

General Specifications:

Type	: Fine bubble tube diffuser-vertical mounting design
Size	: 90 mm dia X 250 mm length
Connection	: 3/4" BSP
Construction	<ul style="list-style-type: none"> • Robust support made of PVC + ABS With 3/4" BSP Male-Female thread • Diffusing tube with special perforation • Fixing element • Low buoyancy construction • Floodable
Bubble size	: 1,0 - 2.0 mm
Perforation size and no.	: 0.6/1 mm and 7380 no. of slits
Tube material	: EPDM/SILICON
Tube Description	: Tube Ø90 mm with staggered horizontal special perforation, Aeration zone approx. 550 cm ² /per piece Unperforated zone with valve effect allows intermittent operation
Tube endurance	: Constant quality for many years Operation times of 7 - 10 years are usual, up to 12 years of operation have been reached, good resistance against ozone, weather influence, aging various acids and lye
Oxygen transfer efficiency	: OTE valve up to 24g O ₂ / Nm ³ X m have been measured by an independent institute for the VMD diffusers OTE values depend on diffuser density, depth of air introduction and the air flow rate
Air-flow range per diffuser	: 0 - 10 m ³ / h X m (excellent air controllability) Suitable for intermittent operation Optimal fumigation range 2 - 6 m ³ / hr. per diffuser
Head loss	: 45 - 92 mbar +/- 10 mbar
Connection	: Nipple 3/4" thread
Application	: Ideal for SAFF System, for high TDS, SS contained effluent



FINE BUBBLE DISC DIFFUSER

AIRFIN®Disc diffusers are compression molded EPDM / Silicon / Viton / PTFE layered membranes with low plasticizer and filler to ensure exceptional quality, strength and longer prudent life.

The diffuser assembly of base and ring are constructed of glass fiber reinforced poly propylene for maximum life and durability. The diffusers incorporate an external triple check valve design to prevent intrusion of liquid or solids into the diffuser or air piping during ON/OFF operating conditions. Precision die cut perforation proprietary design for maximum oxygen transfer efficiency.

MATERIAL AND MECHANICAL PROPERTIES FOR EPDM AND SILICON DISC DIFFUSER/DIFFUSER

Mechanical Parameters	EPDM	SILICON
Material Make up	Polymer 20-22% Carbon Black 45-50% Plasticizer 22-23% Others 3%	Polymer 99% Colour additives 0.1%
Colour	black	Opaque white Milky white Aqua blue
Wall Thickness	2 mm overall	2 mm overall
Hardness (ASTM D-2240)	55± 5 shore "A" 50± 5 shore "A"	60± 5 shore "A"
Tensile strength at break - KG/CM ² (ASTM D - 412)	70 kg/cm ²	60 kg/cm ²
Elongation at break (ASTM D - 412)	450%	600%
Tear strength "die-T" (ASTM D - 624)	7 N/mm	35 N/mm
Environmental Resistance Test		
Ozone resistance 75hrs, 40°C, 50mPa partial Ozone Pressure Non-cracking (ASTM D 1171 - 94)	No Cracks	Pass
Low Temp. property -40°C, Non brittle (ASTM D 832 - 92)	Pass	Pass
Density	1.2 g/cm ³ ± 0.5	1.25 g/cm ³ ± 0.5
MAX. Operating Air Temperature °C	60	95
Tension Set @ 100% elongation% (ASTM D - 412.92)	<1.7%	<1.8%

FINE BUBBLE DISC DIFFUSER (DISC 270)

Specifications:

Membrane Material	: EPDM / Silicon / Viton® / PTFE layered EPDM
Base and Ring	: Glass filled Reinforced polypropylene (GFPP)
Connection	: 3/4" inches NPT MALE
Airflow Range	: 0 to 12 m ³ /hr
Standard Design Flow	: 2.5 to 5 m ³ /hr
Perforated area (Active surface Area)	: 0.0375m ²
Nos. of perforation	: 6600
Perforation size	: 1mm
Bubble size	: 0.8 to 1.9 mm
Working area	: 0.2-1.M ² /PCS
Max. allowable air pressure	: 1.5Kg/cm ²
Max. permissible tank depth	: 7.5 m
Weight	: 0.7 Kg



Standard oxygen transfer efficiency (SOTE) and headloss for AIRFIN-DISC-270 performance

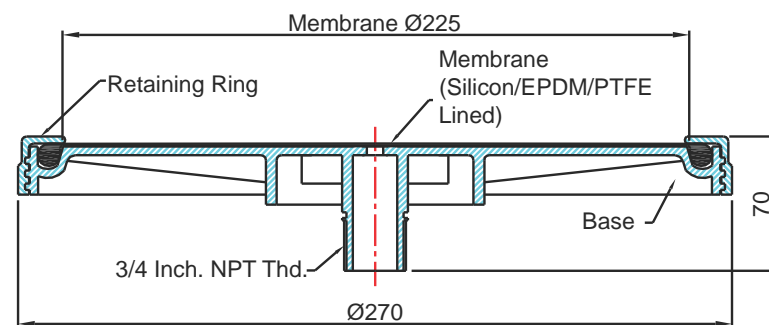
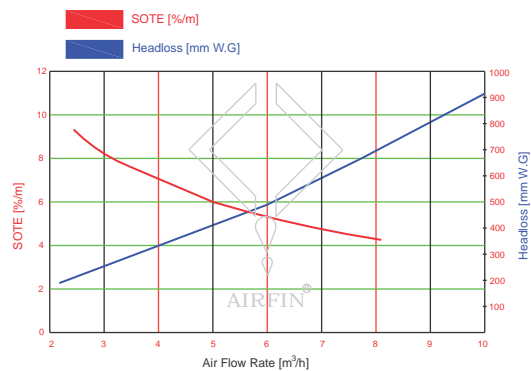

FINE BUBBLE DISC DIFFUSER (DISC 350)

Specifications:

Membrane Material	: EPDM / Silicon / Viton® / PTFE layered EPDM
Base and Ring	: Glass filled Reinforced polypropylene (GFPP)
Connection	: 3/4" inches NPT MALE
Airflow Range	: 0 to 20 m ³ /hr
Standard Design Flow	: 4 to 8.5 m ³ /hr
Perforated area (Active surface area)	: 0.065 m ²
Nos. of perforated	: 10,160 nos.
Perforation size	: 1 mm
Bubble size	: 0.8 to 1.9 mm
Working area	: 0.3 - 1.5M ² /PCS
Max. allowable air pressure	: 1.5 Kg/cm ²
Max. permissible tank depth	: 7.5 m
Weight	: 1.5 Kg



Standard oxygen transfer efficiency (SOTE) and headloss for AIRFIN-DISC-350 performance

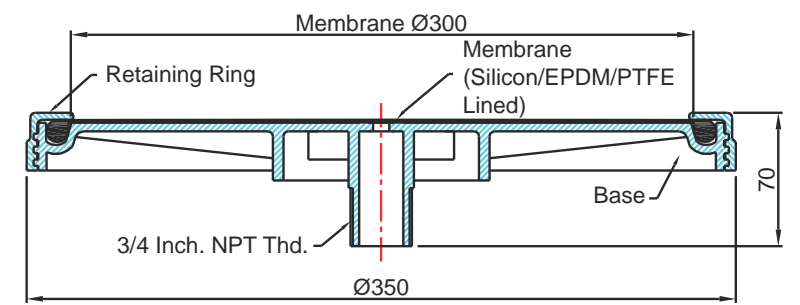
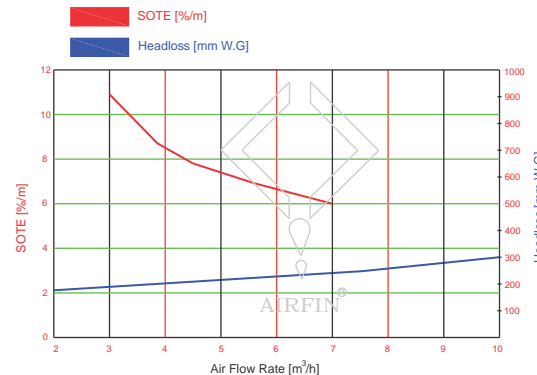

COARSE BUBBLE DISC DIFFUSER(JCB)

Our JCB series Diffusers have been engineered in a simplified design consisting of two parts: The support base and flexible diaphragm. The diaphragm is designed to provide extended life and optimum performance due to its specially formulated EPDM/Silicon rubber material.

APPLICATION:

- Activated sludge waste water treatment
- Equalization basin mixing / aeration
- Industrial waste water treatment
- Oxygen for sludge stabilization
- Aeration of pond and streams
- Aerobic digestors
- Treated water tank agitation
- Mixing purpose for effluent and dosing liquid like Lime, Ferrous, Sulphur solution

JCB 80

Specifications:

- Shape : Disc
- Size dia : 80 mm (3")
- Bubble size : 4 - 5 mm
- Membrane material : EPDM / Silicon
- Membrane support : PP / Steel
- Operating Temp : 35 °C (max 85°C)
- Air discharge from : Top
- Air discharge ports : 10
- Standard Airflow/diffuser : 1 - 5 Nm³/hr
- Air flow Range/diffuser : 1 - 15Nm³/hr
- Min req. Qty for mixing : 2
- End connection male thread : 3/4" BSP / NPT
- Special arrangement : Non clog
- Max pressure allowed : 1 Kg/cm²
- Weight : 40 gm

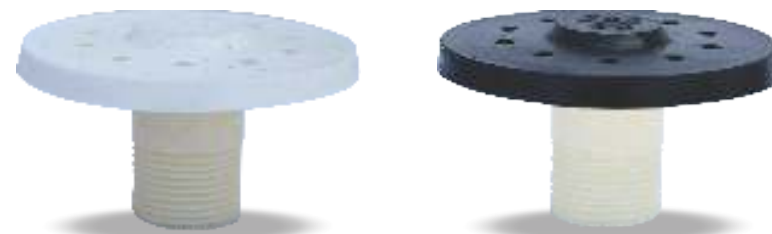
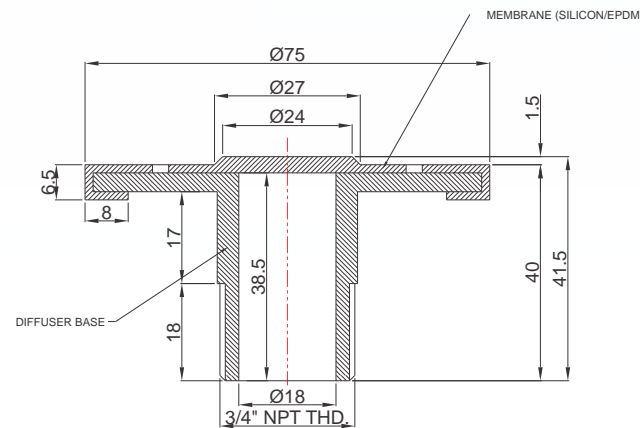

Standard oxygen transfer efficiency (SOTE) and headloss for JCB-80/100/150 performance

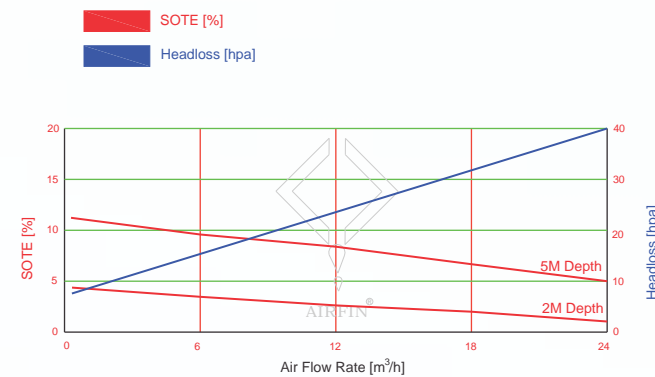

JCB 100

- Shape : Disc
- Size dia : 105 mm (4")
- Bubble size : 4 - 5 mm
- Membrane material : EPDM / Silicon
- Membrane support : GFPP
- Operating Temp : 35 °C (max 85°C)
- Air discharge from : Bottom
- Air discharge ports : 16
- Standard Airflow/diffuser : 10 Nm³/hr
- Air flow Range/diffuser : 2 - 25Nm³/hr
- Min req. Qty for mixing : 1
- End connection male thread : 3/4" NPT
- Special arrangement : Non clog
- Max pressure allowed : 1.5 Kg/cm²
- Weight : 100 gm

Standard oxygen transfer efficiency (SOTE) and headloss for JCB-80/100/150 performance

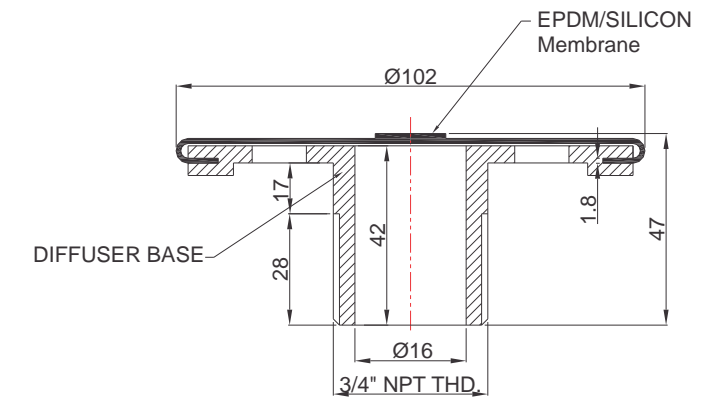
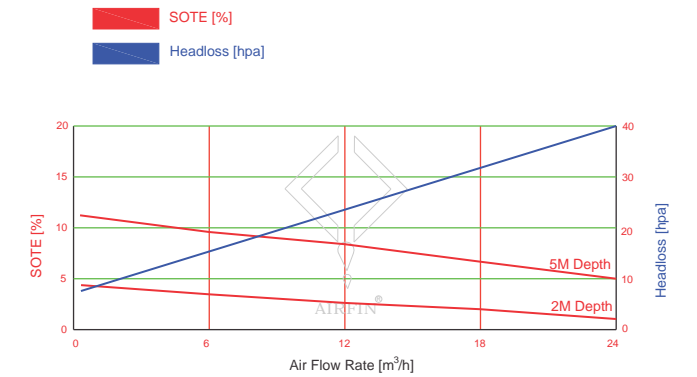

JCB 150 ■

Specifications:

Shape	: Disc
Size dia	: 150 mm (6")
Bubble size	: 4 - 5 mm
Membrane material	: EPDM / Silicon
Membrane support	: ABS
Operating Temp	: 35 °C (max 85°C)
Air discharge from	: Peripheral
Air discharge ports	: 8
Standard Airflow/diffuser	: 15 Nm ³ /hr
Air flow Range/diffuser	: 4 - 25 Nm ³ /hr
Min req. Qty for mixing	: 1
End connection male thread	: ¾" BSP / NPT
Special arrangement	: Non clog
Max pressure allowed	: 1.5 Kg/cm ²
Weight	: 120 gm

Standard oxygen transfer efficiency (SOTE) and headloss for JCB-80/100/150 performance

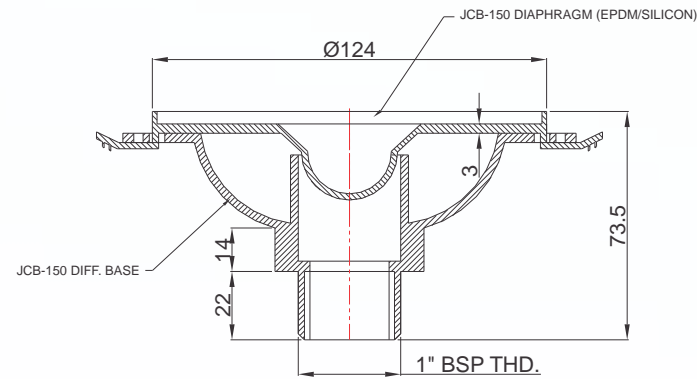
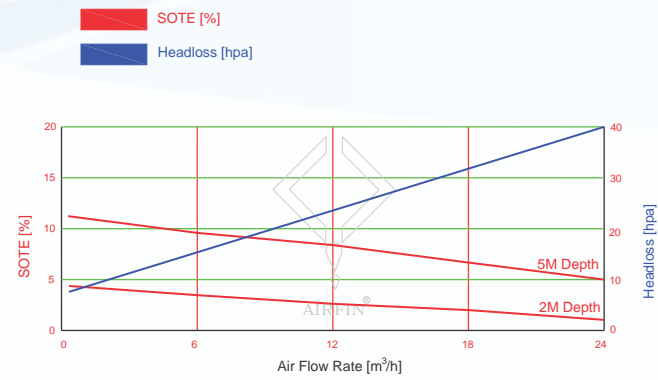

Retrievable Assembly ■

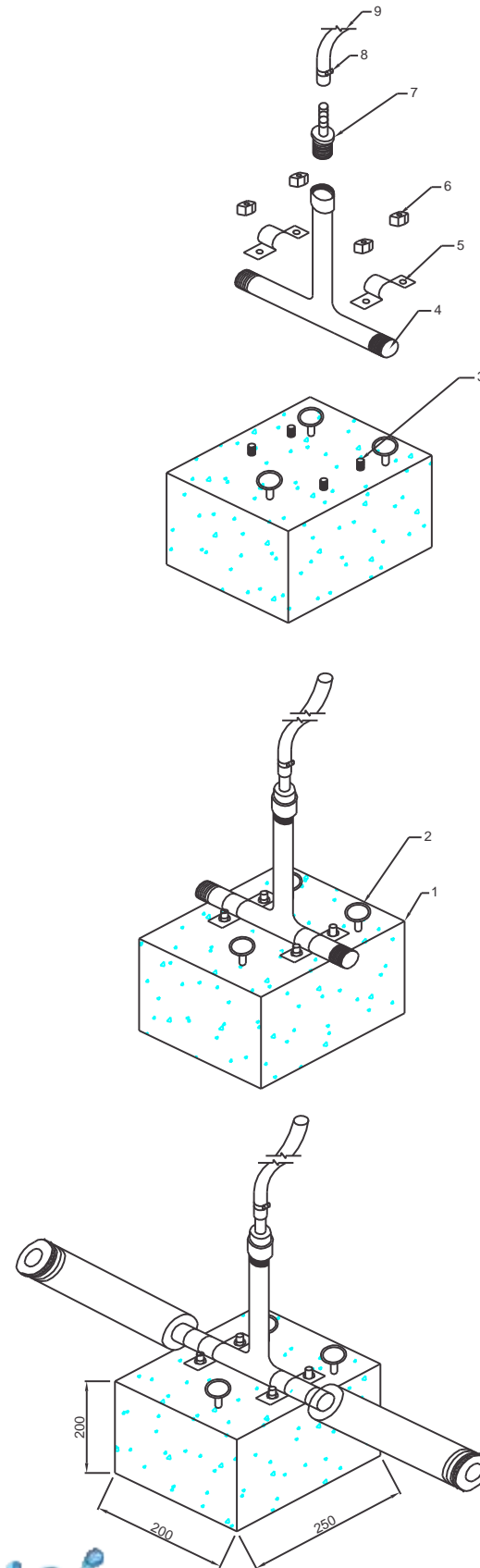

Sr.No	DESCRIPTION	QTY.
1	RCC BLOCK (250 X 200 X 200 MM)	1/UNIT
2	EYE BOLT (Ø6 / 8 / 10 MM)	3/UNIT
3	M-8 / 10 X125 MM SS BOLT (FOR CLAMP)	4/UNIT
4	3/4" / 1" Thd.SS TEE	1/UNIT
5	SS CLAMP FOR TEE (AS PER 3/4" / 1")	2/UNIT
6	M-8 / 10 MM NUT	4/UNIT
7	3/4" / 1" HOSE NIPPLE	1/UNIT
8	HOSE PIPE CLAMP SS (10 / 16 / 25 MM)	1/UNIT
9	BRAIDED HOSE PIPE (ID 10 / 16 / 25 MM)	1/UNIT (AS PER TANK SIZE)

